



Translation of the Original Operating Manual

GM 4700AC
GM 4700AC-H

Version 04/2016

**AirCoat manual gun for flat and
round jet nozzles**

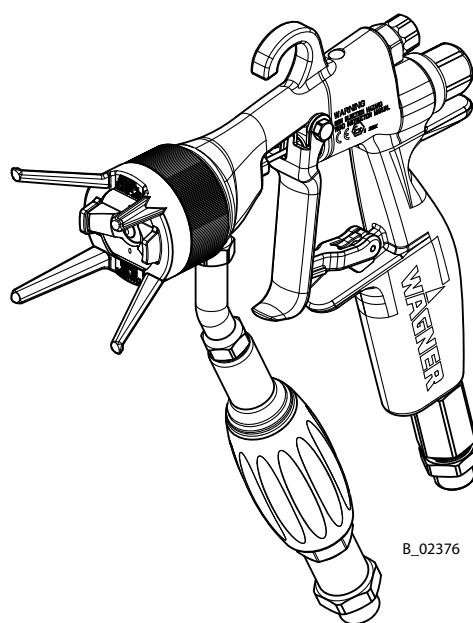

B_02376

CE  II 2G X (Atex)

Table of Contents

1	ABOUT THESE INSTRUCTIONS	6
1.1	Preface	6
1.2	Warnings, Notices and Symbols in these Instructions	6
1.3	Languages	7
1.4	Abbreviations	7
1.5	Terminology for the Purpose of this Manual	8
2	CORRECT USE	9
2.1	Device Type	9
2.2	Type of Use	9
2.3	Use in an Explosion Hazard Area	9
2.4	Safety Parameters	9
2.5	Processible Working Materials	10
2.6	Reasonably Foreseeable Misuse	10
2.7	Residual Risks	11
3	IDENTIFICATION	12
3.1	CE Explosion Protection Identification	12
3.2	Identification "X"	12
3.3	Type Plate	13
4	GENERAL SAFETY INSTRUCTIONS	14
4.1	Safety Instructions for the Operator	14
4.1.1	Electrical Equipment	14
4.1.2	Personnel Qualifications	14
4.1.3	Safe Work Environment	14
4.2	Safety Instructions for Staff	15
4.2.1	Safe Handling of WAGNER Spray Devices	15
4.2.2	Grounding the Device	16
4.2.3	Product Hoses	16
4.2.4	Cleaning and Flushing	17
4.2.5	Handling Hazardous Liquids, Varnishes and Paints	17
4.2.6	Touching Hot Surfaces	18
4.3	Protective and Monitoring Equipment	18
5	DESCRIPTION	19
5.1	Components	19
5.2	Mode of Operation	20
5.3	Protective and Monitoring Equipment	20
5.4	Scope of Delivery	20
5.4.1	Versions for Application up to 25 MPa; 250 bar; 3625 psi	20
5.4.2	Standard Equipment	20
5.5	Data	21
5.5.1	Materials of Paint-wetted Parts	21
5.5.2	Technical Data	21
6	ASSEMBLY AND COMMISSIONING	22
6.1	Training Assembly/Commissioning Staff	22
6.2	Storage Conditions	22
6.3	Installation Conditions	22

Table of Contents

6.4	Assembly and Installation	23
6.4.1	Typical AirCoat Spraying System	23
6.4.2	Ventilation of the Spray Booth	24
6.4.3	Air Supply	24
6.4.4	Product Supply	24
6.5	Grounding	25
6.6	Safety Checks	25
6.7	Preparation of Lacquer	25
6.8	Commissioning	26
6.8.1	Safety Instructions	26
6.8.2	Preparation for Commissioning	26
6.8.3	Commissioning	26
6.8.4	Verifying a Safe Operational Condition	26
7	OPERATION	27
7.1	Training the Operating Staff	27
7.2	Safety Instructions	27
7.2.1	General Rules for Making Adjustments to the Spray Gun	28
7.3	Working	29
7.3.1	Starting to Spray with the AirCoat	29
7.3.2	Adjusting the Spray Pattern	30
7.3.3	Pressure Relief/Work Interruption	31
7.3.4	Changing the AirCoat nozzle	33
7.3.5	Cleaning AirCoat Nozzle	34
7.3.6	Eliminate Nozzle Clogging	34
8	CLEANING AND MAINTENANCE	35
8.1	Cleaning	35
8.1.1	Cleaning Staff	35
8.1.2	Safety Instructions	35
8.1.3	Flushing and Cleaning the Gun	36
8.2	Maintenance	38
8.2.1	Maintenance Staff	38
8.2.2	Safety Instructions	38
8.2.3	Safety Checks	39
8.2.3.1	Grounding Check	39
8.2.3.2	Product Hoses, Tubes and Couplings	40
8.3	Replacing the Product Hose or Air Hose	41
8.4	Changing or Cleaning Filter Insert	42
9	TROUBLE SHOOTING AND RECTIFICATION	44
10	REPAIR WORK	46
10.1	Repair Staff	46
10.2	Safety Instructions	46
10.3	Dismantling of the Gun	47
10.4	Replacing Parts on the Valve Rod	48
10.4.1	Disassembling	48
10.4.2	Replacing Valve Tappet Seals	49
10.4.3	Replacing the Rod Seal	49
10.4.4	Assembling	50

Table of Contents

10.5	Replacing the Nozzle Seal	52
10.6	Replacing the "Air" Sealing Ring	53
10.7	Replacing the Sealing Fitting of the Round Jet Nozzle	54
10.8	Replacing the Spring Cap	55
10.9	Replace Filter Connection (only GM 4700AC)	56
10.9.1	Required Tools and Aids	56
10.9.2	Safety Instructions	56
10.9.3	Disassembly	57
10.9.4	Assembling	58
11	FUNCTION TEST AFTER THE REPAIR	60
12	DISPOSAL	62
13	ACCESSORIES	63
13.1	Round Jet Nozzle Cap	63
13.1.1	Nozzle Inserts RXX	63
13.1.2	Complete Nozzle Screw Joint	63
13.2	Air Caps	64
13.3	Anodized Union Nut	64
13.4	AirCoat Nozzles ACF3000	65
13.5	AirCoat Pre-atomizer Nozzles ACF3000 Plus	65
13.6	Filter Insert	66
13.7	Swivel Joints	66
13.8	Hoses	67
13.9	Nozzle Extensions	67
13.10	Miscellaneous	68
14	SPARE PARTS	69
14.1	How Can Spare Parts Be Ordered?	69
14.2	Spare Parts GM 4700AC	70
14.3	Spare Parts GM 4700AC-H	73
15	WARRANTY AND CONFORMITY DECLARATIONS	76
15.1	Important Notes Regarding Product Liability	76
15.2	Warranty Claim	76
15.3	CE Declaration of Conformity	77
15.4	Reference to German Regulations and Guidelines	78

1 ABOUT THESE INSTRUCTIONS

1.1 PREFACE

The operating manual contains information about safely operating, maintaining, cleaning and repairing the device.

The operating manual is part of the device and must be available to the operating and service personnel.

The device may only be operated by trained personnel and in compliance with this operating manual.

Operating and service personnel should be instructed according to the safety instructions. This equipment can be dangerous if it is not operated according to the instructions in this operating manual.

1.2 WARNINGS, NOTICES AND SYMBOLS IN THESE INSTRUCTIONS

Warning instructions in this operating manual highlight particular dangers to users and to the device and state measures for avoiding the hazard. These warning instructions fall into the following categories:

Danger - immediate risk of danger.
Non-observance will result in death or serious injury.

	⚠ DANGER
	This notice warns you of a hazard! Possible consequences of not observing the warning instructions. The signal word indicates the hazard level. → The measures for preventing the hazard and its consequences.

Warning - possible imminent danger.
Non-observance may result in death or serious injury.

	⚠ WARNING
	This notice warns you of a hazard! Possible consequences of not observing the warning instructions. The signal word indicates the hazard level. → The measures for preventing the hazard and its consequences.

Caution - a possibly hazardous situation.
Non-observance may result in minor injury.

	⚠ CAUTION
	This notice warns you of a hazard! Possible consequences of not observing the warning instructions. The signal word indicates the hazard level. → The measures for preventing the hazard and its consequences.

Notice - a possibly hazardous situation.
Non-observance may result in damage to property.

NOTICE
This notice warns you of a hazard! Possible consequences of not observing the warning instructions. The signal word indicates the hazard level. → The measures for preventing the hazard and its consequences.

Note - provides information about particular characteristics and how to proceed.

1.3 LANGUAGES

The operating manual is available in the following languages:

Language:	Order No.	Language:	Order No.
German	2311729	English	2311730
French	2311731	Dutch	2326027
Italian	2311732	Spanish	2311733
Russian	2328825	Chinese	2328826
Hungarian	2354518	Danish	2369072

1.4 ABBREVIATIONS

Order No.	Order number
ET	Spare part
K	Marking in the spare parts lists
LA	Low Air
HV	for highly viscous materials
LV	for low viscosity materials
Pos	Position
Stk	Number of pieces
SW	Wrench size
GM	Manual gun
AC	AirCoat
H	Processing heated product (hot)
2K	2-component product
DN	Nominal diameter

1.5 TERMINOLOGY FOR THE PURPOSE OF THIS MANUAL

Cleaning	Manual cleaning of devices and device parts with cleaning agent
Flushing	Internal flushing of paint-wetted parts with flushing agent
Product pressure generator	Pump or pressure tank
Staff qualifications	
Trained person	Is instructed in the tasks assigned to him/her, the potential risks associated with improper behavior as well as the necessary protective devices and measures.
Electrically trained person	Is instructed by an electrician about the tasks assigned to him/her, the potential risks associated with improper behavior as well as the necessary protective devices and measures.
Electrician	Can assess the work assigned to him/her and detect possible hazards based on his/her technical training, knowledge and experience in relevant provisions.
Skilled person In accordance with TRBS 1203 (2010)	A person, who, based on his/her technical training, experience and recent vocational experience, has sufficient technical knowledge in the areas of explosion protection, protection from pressure hazards and electric hazards (if applicable) and is familiar with the relevant and generally accepted rules of technology so that he/she can inspect and assess the status of devices and coating systems based on workplace safety.

2 CORRECT USE

2.1 DEVICE TYPE

AirCoat manual gun for manually coating work pieces.

2.2 TYPE OF USE

The gun is suitable for atomizing liquid products, particularly coating products, using the AirCoat process.

2.3 USE IN AN EXPLOSION HAZARD AREA

The device is suitable for use in potentially explosive areas as defined in the 94/9/EC (ATEX) Directive, (see Explosion protection marking Chapter 3.1).



2.4 SAFETY PARAMETERS

WAGNER accepts no liability for any damage arising from incorrect use.

- Use the device only to work with the products recommended by WAGNER.
- Only operate the device as a whole.
- Do not deactivate safety fixtures.
- Use only WAGNER original spare parts and accessories.

The device may only be operated under the following conditions:

- The operating personnel must be trained on the basis of this operating manual.
- The safety regulations listed in this operating manual must be observed.
- The operating, maintenance and repair information in this operating manual must be observed.
- The statutory requirements and accident prevention regulation standards in the country of use must be observed.

2.5 PROCESSIBLE WORKING MATERIALS

Top-coat lacquers, primer paints, corrosion protection, textured lacquers, lyes, staining solvents, clear lacquers, separating agents, etc. with a solvent or water base. If you want to spray working materials other than the aforementioned, please contact a WAGNER representative.

	 WARNING
	<p>Hot coating products! Burns.</p> <ul style="list-style-type: none"> → Wear antistatic protective gloves. → When operating the device with a coating product with a temperature of > 43 °C; 109.4 °F, identify the device with a warning label that says "Warning - hot surface".

Note:

Please contact your local WAGNER dealer and the lacquer manufacturer if you encounter application problems.

2.6 REASONABLY FORESEEABLE MISUSE

The forms of misuse listed below may result in physical injury or property damage:

- unauthorized conversions or modifications to the system;
- processing dry or similar coating products, e.g., powder;
- using defective components, spare parts or accessories other than those described in the "Accessories" chapter of this operating manual;
- continuing work with a defective or kinked product hose;
- working with incorrectly set values;
- processing food.

2.7 RESIDUAL RISKS

Residual risks are risks which cannot be ruled out even in the event of correct use.
If necessary, warning and prohibition signs at the relevant points of risk indicate residual risks.

Residual risk	Source	Consequences	Specific measures	Lifecycle phase
Skin contact with lacquers and cleaning agents	Handling of lacquers and cleaning agents	Skin irritations, allergies	Wear protective clothing Observe safety data sheets	Operation, maintenance, disassembly
Lacquer in air outside the defined working area	Lacquering outside the defined working area	Inhalation of substances hazardous to health	Observe work and operation instructions	Operation, maintenance

3 IDENTIFICATION

3.1 CE EXPLOSION PROTECTION IDENTIFICATION

As defined in the Directive 94/9/EC (ATEX), the device is suitable for use in potentially explosive areas.

Device type: AirCoat manual gun
 Manufacturer: J. Wagner AG
 CH-9450 Altstätten, Switzerland

CE  II 2G X

CE European Communities
 Ex Symbol for explosion protection
 II Device class II
 2 Category 2 (Zone 1)
 G Ex-atmosphere gas
 X Special Notice

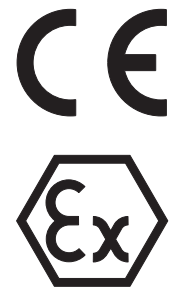

3.2 IDENTIFICATION "X"

X: The maximum surface temperature corresponds to the permissible product temperature. This and the permissible ambient temperature can be found in the "Technical Data" chapter.

Safe handling of WAGNER spray devices

Mechanical sparks can form if the device comes into contact with metal.

In an explosive atmosphere:

- Do not knock or push the device against steel or rusty iron.
- Do not drop the spray gun.
- Use only tools that are made of a permitted material.

Ignition temperature of the coating product

→ Ensure that the ignition temperature of the coating product is above the maximum surface temperature.

Medium supporting atomizing

→ To atomize the product, use only weakly oxidizing gases, e.g., air.

Cleaning

If there are deposits on the surfaces, the device may form electrostatic charges. Flames or sparks can form during discharge.

→ Remove deposits from the surfaces to maintain conductivity.

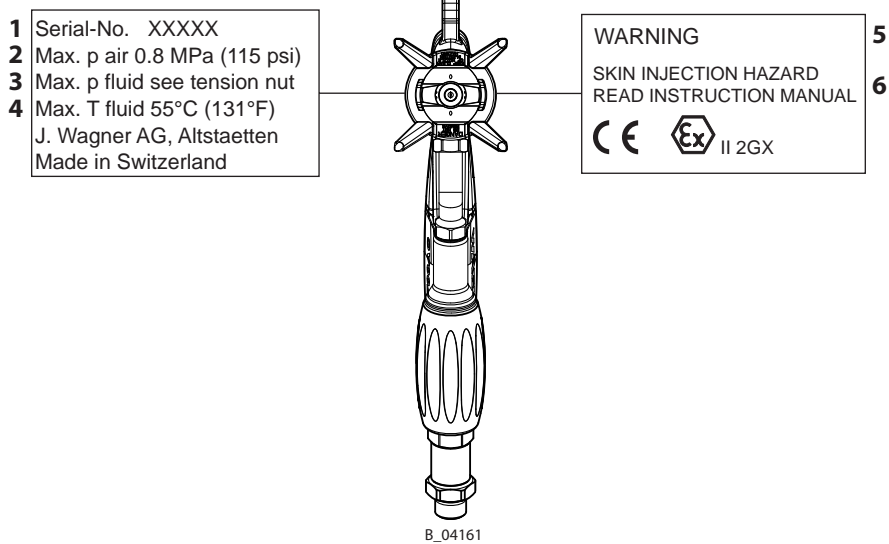
3.3 TYPE PLATE

- 1 Serial number
- 2 Maximum air inlet pressure
- 3 Maximum product pressure see spring cap
- 4 Maximum product temperature
- 5 Warning
- 6 Danger of injury from injection/read operating manual

4 GENERAL SAFETY INSTRUCTIONS

4.1 SAFETY INSTRUCTIONS FOR THE OPERATOR

- Keep this operating manual at hand near the device at all times.
- Always follow local regulations concerning occupational safety and accident prevention.



4.1.1 ELECTRICAL EQUIPMENT

Electrical devices and equipment

- To be provided in accordance with the local safety requirements with regard to the operating mode and ambient influences.
- May only be maintained by skilled electricians or under their supervision.
- Must be operated in accordance with the safety regulations and electrotechnical regulations.
- Must be repaired immediately in the event of problems.
- Must be decommissioned if they pose a hazard.
- Must be de-energized before work is commenced on active parts. Inform staff about planned work. Observe electrical safety regulations.



4.1.2 PERSONNEL QUALIFICATIONS

- Ensure that the device is only operated, maintained and repaired by trained persons.

4.1.3 SAFE WORK ENVIRONMENT

- Ensure that the floor in the working area is static dissipative in accordance with EN 61340-4-1 (resistance must not exceed 100 megohms).
- Ensure that all persons within the working area wear static dissipative shoes. Footwear must comply with EN 20344. The measured insulation resistance must not exceed 100 megohms.
- Ensure that during spraying, persons wear static dissipative gloves. Grounding takes place via the spray gun handle.
- If protective clothing is worn, including gloves, it has to comply with EN 1149-5. The measured insulation resistance must not exceed 100 megohms.
- Paint mist extraction systems/ventilation systems must be fitted on site according to local regulations.
- Ensure that the following components of a safe working environment are available:
 - Product/air hoses adapted to the working pressure.
 - Personal safety equipment (breathing and skin protection).
- Ensure that there are no ignition sources such as naked flames, sparks, glowing wires, or hot surfaces in the vicinity. No smoking.

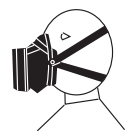

4.2 SAFETY INSTRUCTIONS FOR STAFF

- Always follow the information in this manual, particularly the general safety instructions and the warning instructions.
- Always follow local regulations concerning occupational safety and accident prevention.



4.2.1 SAFE HANDLING OF WAGNER SPRAY DEVICES

The spray jet is under pressure and can cause dangerous injuries.

Avoid injection of paint or flushing agents:

- Never point the spray gun at people.
- Never reach into the spray jet.
- Before all work on the device, in the event of work interruptions and functional faults:
 - Switch off the energy/compressed air supply.
 - Relieve the pressure from the spray gun and device.
 - Secure the spray gun against actuation.
 - In the event of functional faults, remedy the fault as described in the "Troubleshooting" chapter.
- If necessary or at least every 12 months, the liquid ejection devices should be checked for safe working conditions by an expert (e.g., WAGNER Service Technician) in accordance with the guidelines for liquid ejection devices (ZH 1/406 and BGR 500 Part 2 Chapter 2.29 and 2.36).
 - For shut down devices, the examination can be suspended until the next start-up.
- Carry out the work steps as described in the "Pressure Relief" chapter:
 - If pressure relief is required.
 - If the spraying work is interrupted or stopped.
 - Before the device is cleaned on the outside, checked or serviced.
 - Before the spray nozzle is installed or cleaned.



In the event of skin injuries caused by paint or flushing agents:

- Note the paint or flushing agent that you have been using.
- Consult a doctor immediately.

Avoid risk of injury from recoil forces:

- Ensure that you have firm footing when operating the spray gun.
- Only hold the spray gun briefly in a position.

4.2.2 GROUNDING THE DEVICE

In order to avoid electrostatic charging of the device, the device must be grounded. Friction, flowing liquids and air or electrostatic coating processes create charges. Flames or sparks can form during discharge.

- Ensure that the device is grounded for every spraying operation.
- Ground the work pieces to be coated.
- Ensure that all persons inside the working area are grounded, e.g., that they are wearing static dissipative shoes.
- Wear static dissipative gloves when spraying. The grounding takes place via the spray gun handle.



4.2.3 PRODUCT HOSES

- Ensure that the hose material is chemically resistant to the sprayed products and the used flushing agents.
- Ensure that the product hose is suitable for the pressure generated.
- Ensure that the following information can be seen on the high-pressure hose:
 - Manufacturer
 - Permissible operating pressure
 - Date of manufacture
- Make sure that the hoses are laid only in suitable places. Hoses should not be laid in the following places under any circumstances:
 - in high-traffic areas,
 - on sharp edges,
 - on moving parts or
 - on hot surfaces.
- Ensure that the hoses are never run over by vehicles (e.g., fork lifts), or that the hoses are never put under pressure from the outside in any other way.
- Ensure that the hoses are never kinked. Observe maximum bending radii.
- Make sure that the hoses are never used to pull or move the equipment.
- The electrical resistance of the product hose, measured at both valves, must be less than 1 megohm.
- Suction hoses may not be subjected to pressure.



Several liquids have a high expansion coefficient. In some cases their volume can rise with consequent damage to pipes, fittings, etc. and cause fluid leakage.

When the pump sucks liquid from a closed tank, ensure that air or a suitable gas can enter the tank. Thus a negative pressure is avoided. The vacuum could implode the tank (squeeze) and can cause it to break. The tank would leak and the liquid would flow out.

The pressure created by the pump is a multiplication of the inlet air pressure.

4.2.4 CLEANING AND FLUSHING

- Relieve the pressure from the device.
- De-energize the device electrically.
- Preference should be given to non-flammable cleaning and flushing agents.
- Observe the specifications of the lacquer manufacturer.
- Ensure that the flash point of the cleaning agent is at least 15 K above the ambient temperature or that cleaning is undertaken at a cleaning station with technical ventilation.
- Take measures for workplace safety (see Chapter 4.1.3).
- When commissioning or emptying the device, please note that an explosive mixture may temporarily exist inside the lines and components of equipment:
 - depending on the coating product used,
 - depending on the flushing agent (solvent) used,
 explosive mixture inside the lines and items of equipment.
- Only electrically conductive tanks may be used for cleaning and flushing agents.
- The tanks must be grounded.



An explosive gas/air mixture forms in closed tanks.

- Never spray into a closed tank when using solvents for flushing.

External cleaning

When cleaning the exterior of the device or its parts, also observe the following:

- Disconnect the pneumatic supply line.
- Use only moistened cloths and brushes. Never use abrasive agents or hard objects and never spray cleaning agents with a gun. Cleaning the device must not damage it in any way.
- Ensure that no electrical component is cleaned with nor even immersed into solvent.

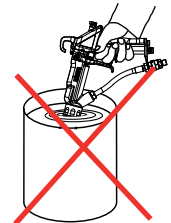

4.2.5 HANDLING HAZARDOUS LIQUIDS, VARNISHES AND PAINTS

- When preparing or working with lacquer and when cleaning the device, follow the working instructions of the manufacturer of the lacquers, solvents and cleaning agents being used.
- Take the specified protective measures, in particular wear safety goggles, protective clothing and gloves, as well as skin protection cream if necessary.
- Use a mask or breathing apparatus if necessary.
- For sufficient health and environmental safety: Operate the device in a spray booth or on a spraying wall with the ventilation (extraction) switched on.
- Wear suitable protective clothing when working with hot products.



4.2.6 TOUCHING HOT SURFACES

- Only touch hot surfaces if you are wearing protective gloves.
- When operating the device with a coating product with a temperature of > 43 °C; 109.4 °F:
 - Identify the device with a warning label "Warning - hot surface".

Order No.

9998910 Instruction label

9998911 Protection label

Note: Order the two stickers together.



4.3 PROTECTIVE AND MONITORING EQUIPMENT

- Protective and monitoring equipment must not be removed, modified or rendered unusable.
- Regularly check for perfect functioning.
- If defects are detected on protective and monitoring equipment, the system must not be operated until these defects are remedied.

5 DESCRIPTION

5.1 COMPONENTS

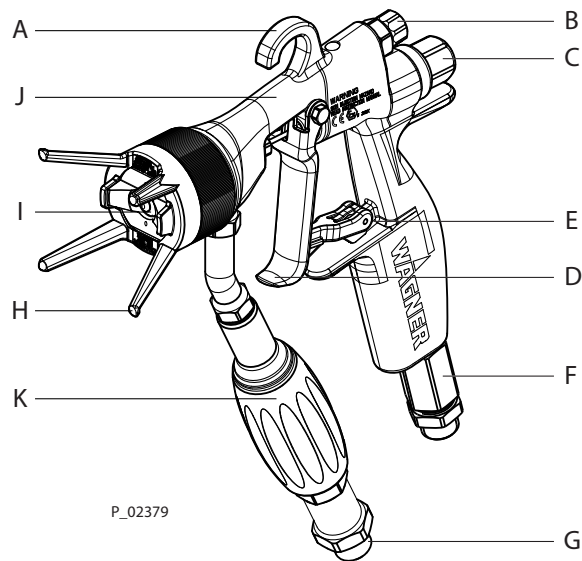

	Designation
A	Suspension hook
B	Regulator for shaping air
C	Spring cap
D	Trigger
E	Trigger locking device
f	Air connection
G	Fluid inlet
H	Union nut with nozzle protection
I	Nozzle / Air cap
J	Gun housing
K	Turning handle with filter housing

5.2 MODE OF OPERATION

If the trigger (D) is operated when the trigger locking device (E) is released, then the air valve opens first. Atomizing air flows through the air connection (F) to the air cap (I). The product valve first opens when approx. 1/2 of the trigger's path has been covered. The quantity of air for the atomization of the jet spray is preset via the external air automatic controller. The spray pattern can be adjusted using the shaping air regulator (B).

5.3 PROTECTIVE AND MONITORING EQUIPMENT

The spray gun is secured with the locking device (E) (the locking device turned in the spraying direction and fastened in the groove).

5.4 SCOPE OF DELIVERY

This AirCoat manual gun is available in two different versions. The choice of air cap and nozzle depends on the application, therefore these components are not included in the scope of delivery. A selection guide for gun accessories can be found in Chapter 13.

5.4.1 VERSIONS FOR APPLICATION UP TO 25 MPa; 250 BAR; 3625 PSI

Stk	Order No.	Designation
1	2313585	GM 4700AC 25 MPa, NPSM1/4" product connection
1	2315700	GM 4700AC-H 35 MPa, NPSM1/4" product connection (H = for processing heated product)

5.4.2 STANDARD EQUIPMENT

The standard equipment for guns includes:

Stk	Order No.	Designation
1	2316429	CE Declaration of Conformity
1	2311729	Operating manual German
1	see Chapter 1.3	Operating manual in local language
1	394335	Spring cap 16 MPa; 160 bar; 2320 psi

For special versions the delivery note applies.

5.5 DATA

5.5.1 MATERIALS OF PAINT-WETTED PARTS

Metals		Plastics	
Carbide	Stainless steel 1.4305	POM	FPM
Stainless steel 1.4301	Stainless steel 1.4104	PTFE	PA

5.5.2 TECHNICAL DATA

Description	Units	AirCoat manual gun	
		GM 4700AC	GM 4700AC-H
Maximum air inlet pressure	MPa; psi; bar	0.8; 120; 8	
Maximum product pressure *	MPa; psi; bar	25; 3625; 250 (16; 2320; 160*)	35; 5076; 350 (16; 2320; 160*)
Fluid inlet	inch	NPSM 1/4"	
Air connection	inch	G1/4"	
Filter **	Mesh	50, 100, 150, 200	
Weight	g; oz	595 g; 20.9 oz	
pH range of the product	pH	3.5 - 9.0	
Maximum product temperature	°C; °F	55; 131	80; 176
Maximum air temperature	°C; °F	43; 109	
Sound level at 0.3 MPa; 3 bar; 43.5 psi air pressure and 11 MPa; 110 bar; 1549 psi product pressure***	dB(A)	< 82	

* Spring cap type 16 MPa; 160 bar; 2320 psi is included

** For filter sizes, see Chapter 13.6

*** A-rated sound pressure level measured at 0.5 m distance, Lpa 0.5m in accordance with DIN EN 14462: 2005.

Dimensions

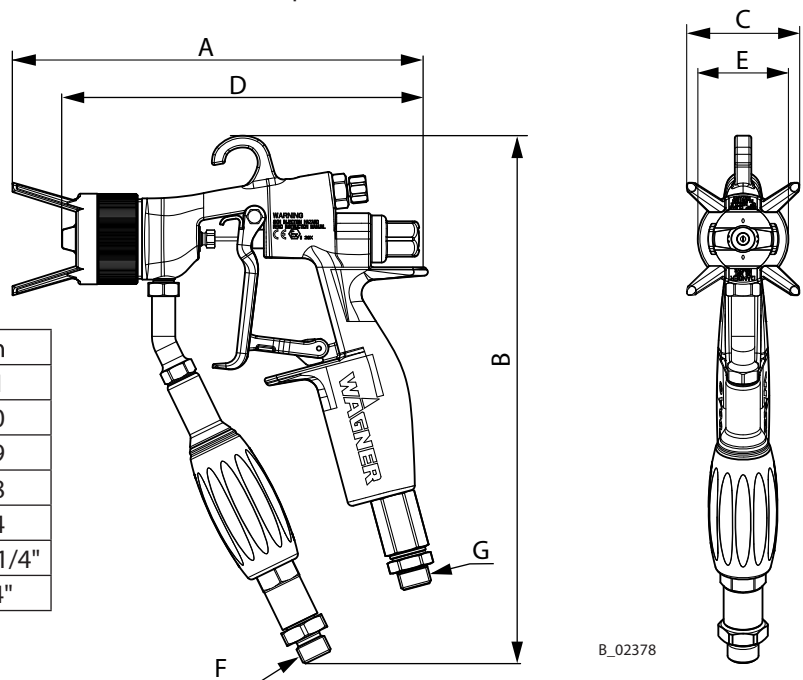

Measurement	mm	inch
A	173	6.81
B	216	8.50
C	48	1.89
D	152	5.98
E	39	1.54
F	-	NPSM 1/4"
G	-	G1/4"



B_02378

6 ASSEMBLY AND COMMISSIONING

6.1 TRAINING ASSEMBLY/COMMISSIONING STAFF

	 WARNING
	<p>Incorrect installation/operation! Risk of injury and damage to the device.</p> <ul style="list-style-type: none"> → The assembly and commissioning staff must have the technical skills to safely commission the device. → When assembling, commissioning and carrying out all work, read and follow the operating manuals and safety regulations for the additionally required system components.

A skilled person must check to ensure that the device is in a reliable state after it is installed and commissioned.

6.2 STORAGE CONDITIONS

Until the point of assembly, the device must be stored in a dry location, free from vibrations and with a minimum of dust. The device must be stored in closed rooms.

The air temperature at the storage location must be between -20 °C and +60 °C (-4 °F and +140 °F).

The relative air humidity at the storage location must be between 10 and 95% (without condensation).

6.3 INSTALLATION CONDITIONS

The air temperature at the installation site must be in a range between 0 °C and +40 °C; +32 °F and +132 °F.

The relative air humidity at the installation site must be between 10 and 95% (without condensation).

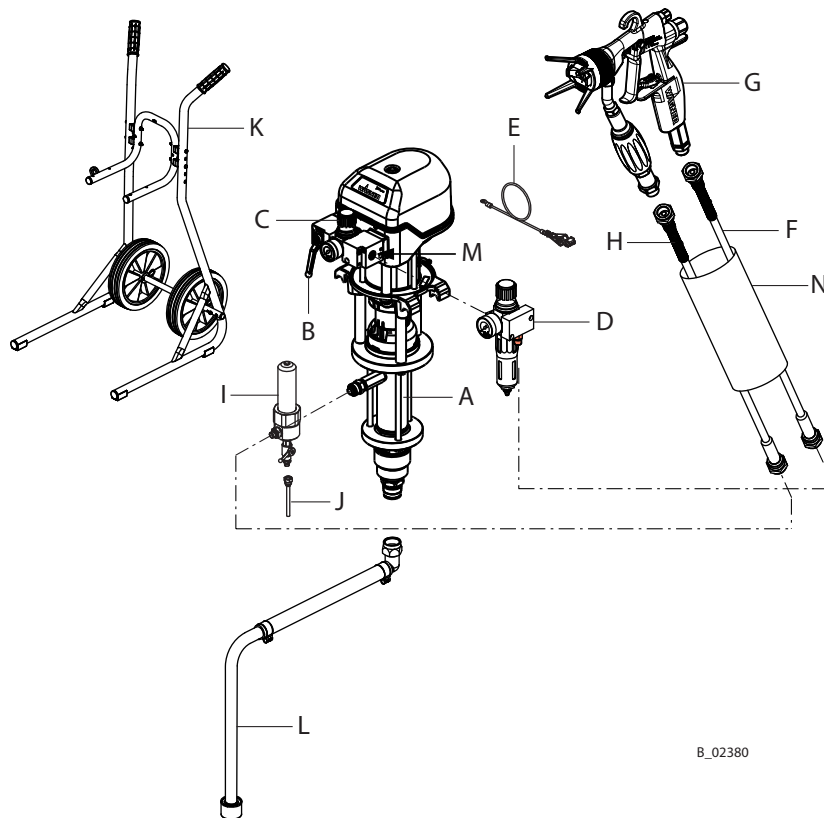
6.4 ASSEMBLY AND INSTALLATION**6.4.1 TYPICAL AIRCOAT SPRAYING SYSTEM**



B_02380

A	Product pump	H	High-pressure product hose, electrically conductive
B	Pressure air shut-off valve	I	High-pressure filter/fluid pressure release
C	Pressure regulator	J	Return line
D	Air pressure regulator with air filter	K	Pump mounting trolley
E	Grounding cable	L	Suction system
f	Air hose	M	Compressed air main
G	AirCoat manual gun	N	Protective hose

The AirCoat manual gun GM 4700AC must be combined with various components to make up a spraying system. The system shown in the figure is only one example of an AirCoat spraying system. Your WAGNER distributor would be happy to assist you in creating a spraying system solution that meets your individual needs.

You must familiarize yourself with the operating manuals and the safety regulations for all additional system components required before starting with commissioning.

6.4.2 VENTILATION OF THE SPRAY BOOTH



	 WARNING
	<p>Toxic and/or flammable vapor mixtures! Risk of poisoning and burns.</p> <ul style="list-style-type: none"> → Operate the device in a spray booth approved for the working materials. <li style="text-align: center;">– or – → Operate the device on an appropriate spraying wall with the ventilation (extraction) switched on. → Observe national and local regulations for the exhaust air speed.

6.4.3 AIR SUPPLY

The use of an air filter with air regulator (D) ensures that only dry, clean atomizing air gets into the spray gun! Dirt and moisture in the atomizing air worsens the spraying quality and spraying pattern.



6.4.4 PRODUCT SUPPLY

NOTICE
<p>Impurities in the spraying system! Spray gun blockage, products harden in the spraying system.</p> <p>→ Flush the spray gun and paint supply with a suitable flushing agent.</p>

	 WARNING
	<p>Bursting hose, bursting threaded joints! Danger to life from injection of product.</p> <ul style="list-style-type: none"> → Ensure that the hose material is chemically resistant to the sprayed products. → Ensure that the spray gun, threaded joints and product hose between the device and the spray gun are suitable for the pressure generated in the device. → Ensure that the following information can be seen on the high-pressure hose: <ul style="list-style-type: none"> - Manufacturer - Permissible operating pressure - Date of manufacture

6.5 GROUNDING

	 WARNING
	<p>Discharge of electrostatically charged components in atmospheres containing solvents! Explosion hazard from electrostatic sparks or flames.</p> <p>→ Ground all device components. → Ground the work pieces to be coated.</p>

	 WARNING
	<p>Heavy paint mist if grounding is insufficient! Danger of poisoning. Insufficient paint application quality.</p> <p>→ Ground all device components. → Ground the work pieces to be coated.</p>

A conductive connection (potential equalization cable) must be established between original bundles and the equipment.

6.6 SAFETY CHECKS

→ Carry out safety checks in accordance with Chapter 8.2.3.

6.7 PREPARATION OF LACQUER

The viscosity of the lacquer is of great importance. The best spraying results are obtained with values between 80 and 260 milli Pascal x Sec (mPas).

Please also read the technical data sheet of the lacquer for optimal processing, viscosity adjustment and intermixing of the product.

6.8 COMMISSIONING

6.8.1 SAFETY INSTRUCTIONS

- Observe the safety instructions in Chapter 4 and Chapter 8.1.2.
- Observe the general rules for making adjustments to the spray gun. → Chapter 7.2.1.

6.8.2 PREPARATION FOR COMMISSIONING

NOTICE

Impurities in the spraying system!

Spray gun blockage.

- Flush the spray gun and paint supply with a suitable flushing agent before commissioning.

6.8.3 COMMISSIONING

1. Secure the spray gun.
2. Connect the product hose to the spray gun and product supply system.
3. Connect air hose to spray gun and to oil-free, dry air supply.
4. For guns with filters, insert a suitable filter (see Chapter 13.6 regarding filter inserts).
5. Fit nozzle on nozzle seal. Fit air cap over nozzle. Note the flattened parts (X) on the nozzle and in the air cap. Fit the union nut with nozzle guard and tighten by hand.
6. Visually check the permissible pressures for all the system components.
7. Make sure that the device and all other conductive parts within the work area are grounded.
8. To perform a leak test on the entire installation, the product pressure is slowly increased in increments using a suitable medium until the maximum pressure indicated on the type plate is reached.

Note:

Set the operating pressure to 100 bar; 10 MPa; 1450 psi.

Pull the trigger and check whether the gun closes cleanly upon release.

9. Relieve the pressure of the spray gun and product pressure generator and secure the spray gun.

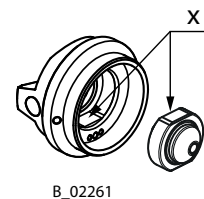

B_02261

6.8.4 VERIFYING A SAFE OPERATIONAL CONDITION

A skilled person must check to ensure that the device is in a reliable state after it is installed and commissioned.



This includes:

- Carry out a safety checks in accordance with Chapter 8.2.3.





7 OPERATION

7.1 TRAINING THE OPERATING STAFF

	 WARNING
	<p>Incorrect operation! Risk of injury and damage to the device.</p> <ul style="list-style-type: none"> → The operating staff must be qualified to operate the entire system. → The operating staff must be familiar with the potential risks associated with improper behavior as well as the necessary protective devices and measures. → Before work commences, the operating staff must receive appropriate system training.



7.2 SAFETY INSTRUCTIONS



- Observe the general rules for making adjustments to the spray gun (see Chapter 7.2.1).
- Observe safety instructions in Chapter 4.

	 WARNING
	<p>Incorrect operation! Risk of injury and damage to the device.</p> <ul style="list-style-type: none"> → If contact with paints or cleaning agents causes skin irritation, appropriate precautionary measures must be taken, e.g., wearing protective clothing. → The footwear worn by operating staff must comply with EN ISO 20344. The measured insulation resistance must not exceed 100 megohms. → The protective clothing, including gloves, must comply with EN ISO 1149-5. The measured insulation resistance must not exceed 100 megohms.

7.2.1 GENERAL RULES FOR MAKING ADJUSTMENTS TO THE SPRAY GUN

→ Observe **safety instructions** in Chapter 4.

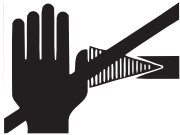
	 WARNING
	<p>Unintentional putting into operation! Risk of injury.</p> <p>Before any work on the device, in the event of work interruptions and malfunctions:</p> <ul style="list-style-type: none"> → Switch off the energy/compressed air supply. → Relieve the pressure from the spray gun and unit. → Secure the spray gun against actuation. → In the event of functional faults, remedy the fault as described in the "Troubleshooting and rectification" chapter.

	 WARNING
	<p>High-pressure spray jet! Danger to life from injecting paint or solvent.</p> <ul style="list-style-type: none"> → Never reach into the spray jet. → Never point the spray gun at people. → Consult a doctor immediately in the event of skin injuries caused by paint or solvent. Inform the doctor about the paint or solvent used. → Never seal defective high-pressure parts; instead relieve the pressure from them and replace them immediately. → Wear the appropriate protective clothing, gloves, eyewear and respiratory protection.

7.3 WORKING

Ensure that:

- the regular safety checks are carried out in accordance with Chapter 8.2.3,
- commissioning is carried out in accordance with Chapter 6.8.

7.3.1 STARTING TO SPRAY WITH THE AIRCOAT

1. Start up with product supply set to approx. 8 MPa; 80 bar; 1160 psi operating pressure.
2. Spray (release locking device and pull trigger) and at the same time observe how the product is atomizing.
3. Set the fluid pressure on the product pump to a point where good product atomization is achieved.
4. Open the air pressure regulator for the atomizing air and adjust it so that an optimal atomization is achieved. (The interrelation between spray pattern and atomizing air is shown in the figure below).
5. Use the shaping air controller on the gun to adjust the shaping air to atomizing air ratio until the optimal spray pattern is achieved.

Note:

Repeat points 3, 4 and 5 until the optimum spray pattern is reached (iterative process).

Spray pattern shapes:



No atomizing air



Too little atomizing air



B_00071

Correct amount of atomizing air

Note:

The flow rate can be changed by:

- changing the product pressure or
- using a different flat jet nozzle (see Chapter 7.3.4 and Chapter 13).

7.3.2 ADJUSTING THE SPRAY PATTERN

The spray pattern can be adjusted to suit the object being sprayed using the shaping air regulator. The illustration shows the influence of the shaping air regulator on the spraying pattern. Other nozzle sizes can be mainly used to obtain larger or smaller spraying patterns.

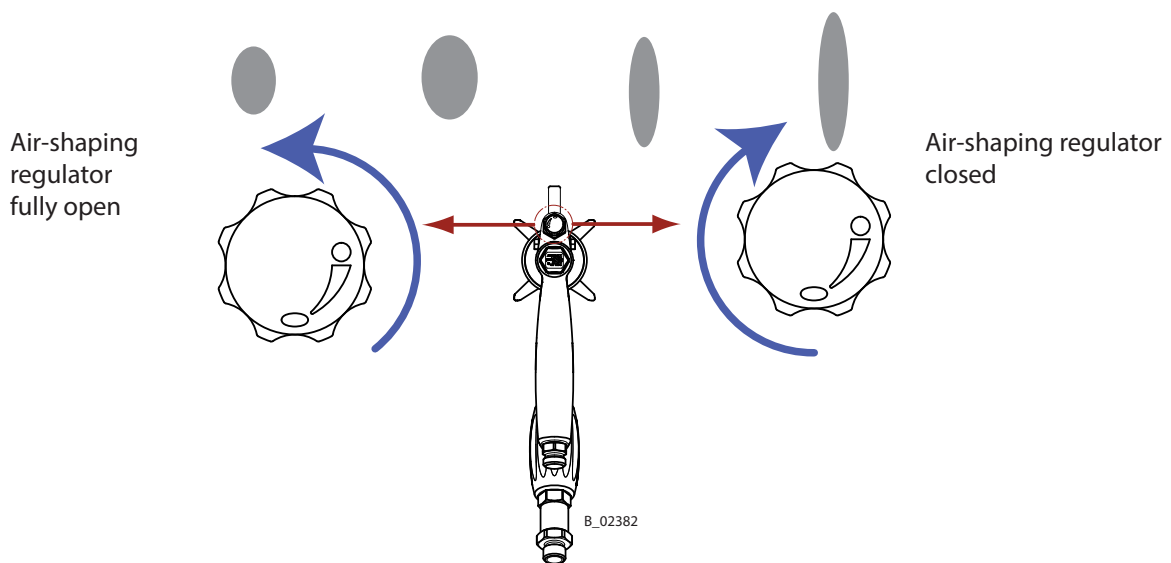

7.3.3 PRESSURE RELIEF/WORK INTERRUPTION



The pressure must always be relieved:

- when the spraying tasks are finished,
- before carrying out maintenance work on the spraying system,
- before carrying out cleaning tasks on the spraying system,
- before moving the spraying system to another location,
- if something must be checked on the spraying system,
- if the nozzle or the filter is removed from the spray gun.

The components for pressure relief on a CE-compliant spray system include:

- Air cock with pressure relief hole mounted between compressed air source and pneumatic pump.
- Product pressure relief valve mounted between pump and spray gun.

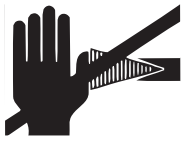
Please read the general safety instructions in Chapter 4.

	 WARNING
	<p>High-pressure spray jet! Danger to life from injecting paint or solvent.</p> <ul style="list-style-type: none">→ Never reach into the spray jet.→ Never point the spray gun at people.→ Consult a doctor immediately in the event of skin injuries caused by paint or solvent. Inform the doctor about the paint or solvent used.→ Never seal defective high-pressure parts; instead relieve the pressure from them and replace them immediately.→ Wear the appropriate protective clothing, gloves, eyewear and respiratory protection.

Pressure relief procedure:

1. Secure the spray gun with the locking device.
2. Close air supply to pump and relieve air pressure in air motor.
3. Release the trigger locking device on the spray gun.
4. Press the electrically conductive part of the spray gun against grounded metal tank for return product and open the spray gun using the trigger; keep it open until no further overpressure is detected.
5. Secure the spray gun with the locking device.
6. Open product pressure relief valve (see system description) and leave open.

If the pressure is still not completely relieved after this:

- **If the nozzle is obstructed:** slowly loosen the union nut to release the residual pressure.
- **If product hose is obstructed:** slowly loosen the hose connections to release the remaining pressure.

Note:

Always follow the procedure described above if pressure relief is specified in the instructions.

7.3.4 CHANGING THE AIRCOAT NOZZLE**NOTICE****Defective AirCoat nozzle!**

Insufficient paint application quality.

→ Do not use sharp-edged objects to treat carbide on the AirCoat nozzle.

1. Relieve the pressure on the spray gun and product pressure generator.
2. Secure the spray gun with the locking device.
3. Unscrew union nut (A).
4. Remove air cap (B).
5. Press AirCoat nozzle (C) out of air cap (B) by hand and treat with cleaning agent until all remaining paint has been dissolved.
6. **Assembly:**
Fit AirCoat nozzle (C) in nozzle seal (D).
7. Fit air cap (B) over nozzle (C). Note the flattened parts (X) on the nozzle and in the air cap.
8. Fit the union nut with nozzle guard (A) and tighten by hand.

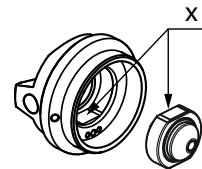

B_02261

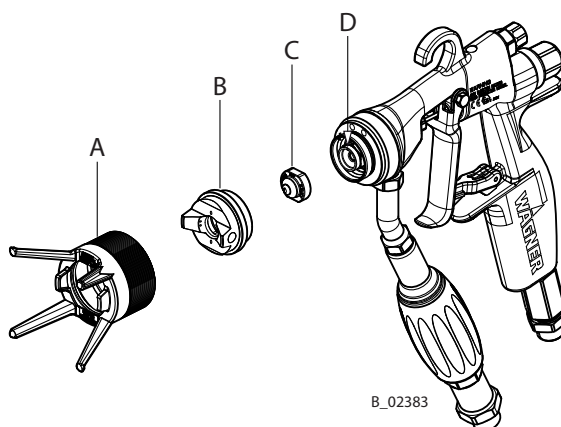

B_02383

7.3.5 CLEANING AIRCOAT NOZZLE

For disassembly and assembly of AirCoat nozzles, see section 7.3.4.

AirCoat nozzle (C) can be placed into a cleaning solvent which has been recommended by the paint manufacturer.

7.3.6 ELIMINATE NOZZLE CLOGGING

1. Relieve the pressure of the spray gun and device.
2. Secure the spray gun with the locking device.
3. Unscrew the union nut with nozzle guard (A).
4. Remove air cap (B).
5. Push AirCoat nozzle (C) out of air cap (B) by hand and place on nozzle seal (D) the other way round with the nozzle tip towards the rear.
6. Refit air cap (B) on nozzle (C). Note the flattened parts (X) on the nozzle and in the air cap.
7. Screw the union nut with nozzle guard (A) over the air cap (B) onto the spray gun and tighten by hand.
8. Switch the product pressure back on.
9. Turn the locking device to the spraying position and briefly pull trigger.
10. When the blockage has been flushed out, secure the spray gun with the trigger locking device.
11. Relieve the pressure of the spray gun and device.
12. Unscrew the union nut with nozzle guard (A).
13. Remove air cap (B) and push AirCoat nozzle (C) out by hand. Clean the nozzle and put it back on nozzle seal (D) in the spray position.
14. Refit air cap (B) on nozzle (C).
Note the flattened parts (X) on the nozzle and in the air cap.
15. Screw the union nut with nozzle guard (A) over the air cap (B) onto the spray gun and tighten by hand.
16. Switch the product pressure and the air pressure back on.

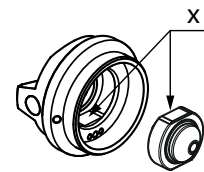

B_02261

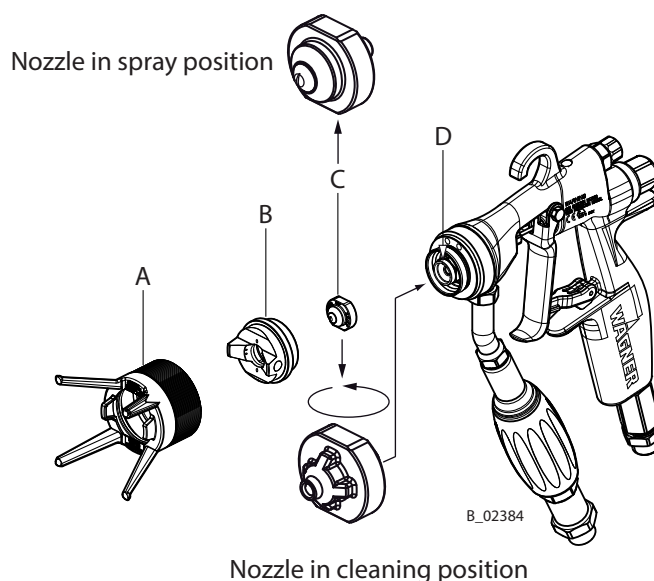

B_02384

8 CLEANING AND MAINTENANCE

8.1 CLEANING

8.1.1 CLEANING STAFF

Cleaning work should be undertaken regularly and carefully by qualified and trained staff. They should be informed of specific hazards during their training.

The following hazards may arise during cleaning work:

- Health hazard from inhaling solvent vapors
- Use of unsuitable cleaning tools and aids

8.1.2 SAFETY INSTRUCTIONS

	! DANGER
	<p>Exploding gas / air mixture! Danger to life from flying parts and burns. → Never spray into a closed tank. → Ground the tank.</p>

	! WARNING
	<p>Explosive atmosphere! Explosive gases are produced when aluminum comes into contact with halogenated hydrocarbons. → To clean aluminum, do not use liquids containing halogenated hydrocarbons.</p>

8.1.3 FLUSHING AND CLEANING THE GUN

NOTICE

Flushing agent in the air duct!

Functional faults caused by swollen seals.

- Always point the spray gun down when cleaning.
- Ensure that neither paint nor flushing agent enters the air duct.
- Never immerse the spray gun in cleaning agent.

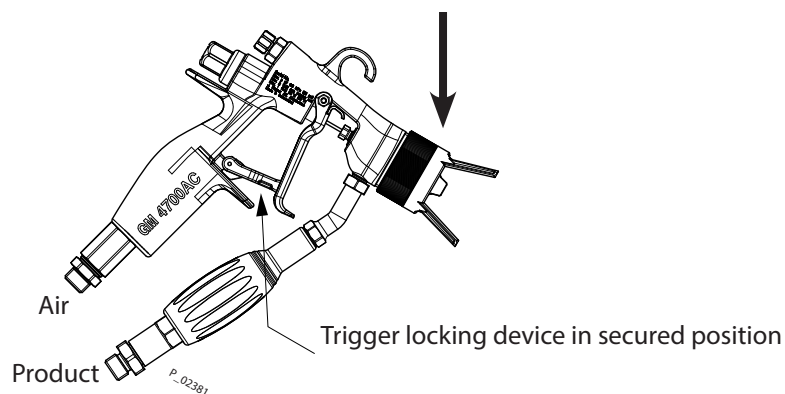

- Observe safety instructions in Chapter 4.

The spray gun and the device must be cleaned and flushed daily. The cleaning/flushing agents used for cleaning or flushing must correspond with the working material.

**DANGER****Incorrect maintenance/repair!**

Danger to life and equipment damage.

- Only a WAGNER service center or a suitably trained person may carry out repairs and replace parts.
- Only repair and replace parts that are listed in the "Spare parts" chapter and that are assigned to the unit.
- Before all work on the device and in the event of work interruptions:
 - Switch off the energy supply and the compressed air supply.
 - Relieve the pressure from the spray gun and device.
 - Secure the spray gun against actuation.
- Observe the operating and service manual for all work.

Note:

Methylene chloride is not recommended as an agent for flushing or cleaning the spray gun or other system components.

1. Relieve the pressure on the spray gun and product pressure generator in accordance with Chapter 7.3.3.
2. Secure the spray gun with the locking device.
3. Connect the solvent supply.
4. Dismount AirCoat nozzle and clean separately (see Chapter 7.3.4 and 7.3.5).
5. Raise the pressure of the rinsing agent supply up to a maximum of 4 MPa; 40 bar; 580 psi and thoroughly rinse the spray gun.
6. Relieve the pressure on the spray gun and product pressure generator.
7. Secure the spray gun with the locking device.
8. Clean the spray gun body with a cleaning agent recommended by the lacquer manufacturer and dry with a cloth or blow gun.

8.2 MAINTENANCE

8.2.1 MAINTENANCE STAFF

Maintenance work should be undertaken regularly and carefully by qualified and trained staff. They should be informed of specific hazards during their training.

The following hazards may arise during maintenance work:

- Health hazard from inhaling solvent vapors
- Use of unsuitable tools and aids

An authorized person must ensure that the device is checked for being in a reliable state after maintenance work is completed.

8.2.2 SAFETY INSTRUCTIONS

→ Observe the safety instructions in Chapter 4 and Chapter 8.1.2.

Prior to maintenance

- Flush and clean the system. → Chapter 8.1.3.

After maintenance

- Carry out a safety checks in accordance with Chapter 8.2.3.
- Put the system into operation and check for leaks as described in Chapter 6.8.

→ In accordance with the guideline for liquid ejection devices (ZH 1/406 and BGR 500 Part 2 Chapter 2.29 and Chapter 2.36):

- The liquid ejection devices should be checked by an expert (e.g., WAGNER service technician) for their safe working conditions as required and at least every 12 months.
- For shut down devices, the examination can be suspended until the next start-up.



DANGER

Incorrect maintenance/repair!

Danger to life and equipment damage.

- Only a WAGNER service center or a suitably trained person may carry out repairs and replace parts.
- Only repair and replace parts that are listed in the "Spare parts" chapter and that are assigned to the unit.
- Before all work on the device and in the event of work interruptions:
 - Switch off the energy supply and the compressed air supply.
 - Relieve the pressure from the spray gun and device.
 - Secure the spray gun against actuation.
- Observe the operating and service manual for all work.



8.2.3 SAFETY CHECKS

8.2.3.1 GROUNDING CHECK

Every day

Before starting work, carry out a visual check to ensure that the system is grounded.

8.2.3.2 PRODUCT HOSES, TUBES AND COUPLINGS

	 DANGER
	<p>Bursting hose, bursting threaded joints! Danger to life from injection of product and from flying parts.</p> <ul style="list-style-type: none"> → Ensure that the hose material is chemically resistant to the sprayed products and the used flushing agents. → Ensure that the spray gun, threaded joints, and product hose between the device and the spray gun are suitable for the generated pressure. → Ensure that the following information can be seen on the hose: <ul style="list-style-type: none"> - Manufacturer - Permissible operating pressure - Date of manufacture.

The service life of the complete hoses between product pressure generator and application device is reduced due to environmental influences even when handled correctly.

- Check hoses, pipes, and couplings every day and replace if necessary.
- Before every commissioning, check all connections for leaks.
- Additionally, the operator must regularly check the complete hoses for wear and tear as well as for damage at intervals that he/she has set. Records of these checks must be kept.
- The complete hose is to be replaced as soon as one of the two following intervals has been exceeded:
 - 6 years from the date of the hose crimping (see fitting embossing).
 - 10 years from the date of the hose imprinting.

Fitting embossing	Meaning
xxx bar	Pressure
yymm	Crimping date (year/month)
XX	Internal code

Hose imprinting	Meaning
Wagner	Name/Manufacturer
yymm	Date of manufacture (year/month)
xxx bar (xx MPa) e.g., 270 bar (27 MPa)	Pressure
XX	Internal code
DNxx (e.g., DN10)	Nominal diameter

8.3 REPLACING THE PRODUCT HOSE OR AIR HOSE

1. Flush and clean the gun as described in Chapter 8.1.3.
2. Relieve the pressure of gun and device.
3. Secure the gun with the locking device.

Product hose

4. Place the size A open-end wrench on the lower flats of the product connection and hold it in place.
5. Unscrew the product hose nut using the size B open-end wrench.

Air hose

4. Place the size D open-end wrench on the flats of the air connection and hold it in place.
5. Loosen the air hose's nut with a size C open-end wrench.

Assembly:

1. Screw on the product hose or air hose by hand and tighten with the two open-end wrenches.

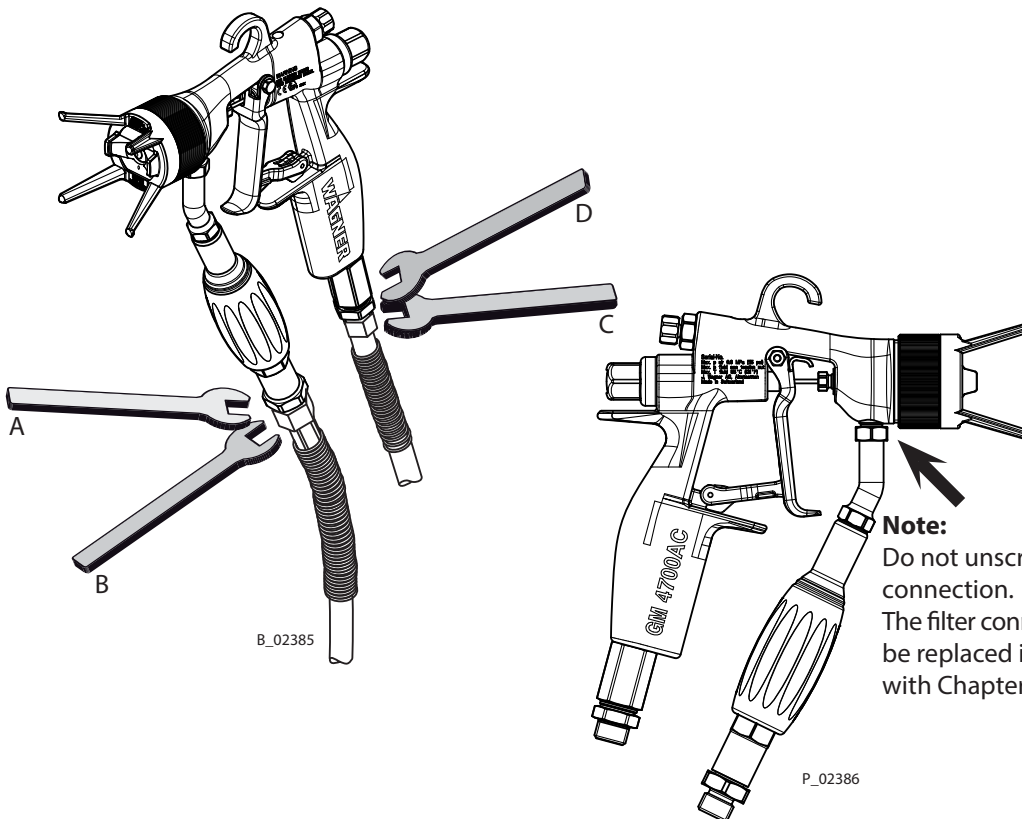

Description	Wrench A Wrench size	Wrench B Wrench size	Wrench C Wrench size	Wrench D Wrench size
GM 4700AC with NPS1/4" filter	19 mm 0.75 inch	19 mm 0.75 inch	17 mm 0.67 inch	17 mm 0.67 inch

8.4 CHANGING OR CLEANING FILTER INSERT

1. Flush and clean the gun as described in Chapter 8.1.3.
2. Relieve the pressure of gun and device.
3. Secure the gun with the locking device.
4. Loosen the filter housing (67) manually with turning handle (66) and unscrew it. When the product hose together with filter housing and filter insert has been exposed, push the rotary handle (66) back onto the upper filter connection.
5. Pull the filter insert (64) out of the filter housing (67).
6. Thoroughly clean all parts with flushing agent.

Assembly:

7. Push the cleaned or new filter insert (64) with opening downwards into the filter housing (67).
8. Insert the filter housing (67) into the turning handle, screw in manually with the turning handle and tighten.

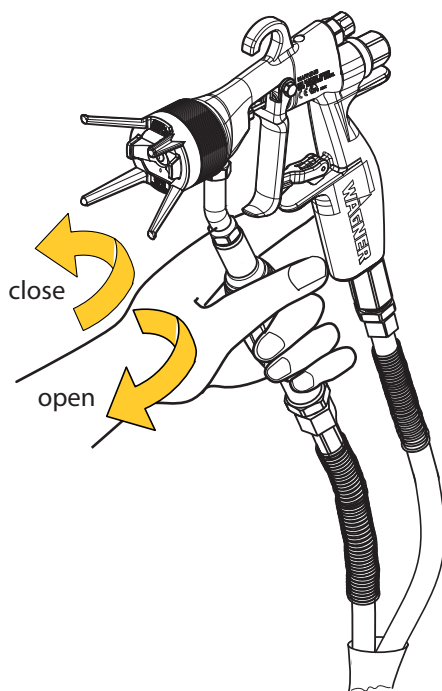

B_03649

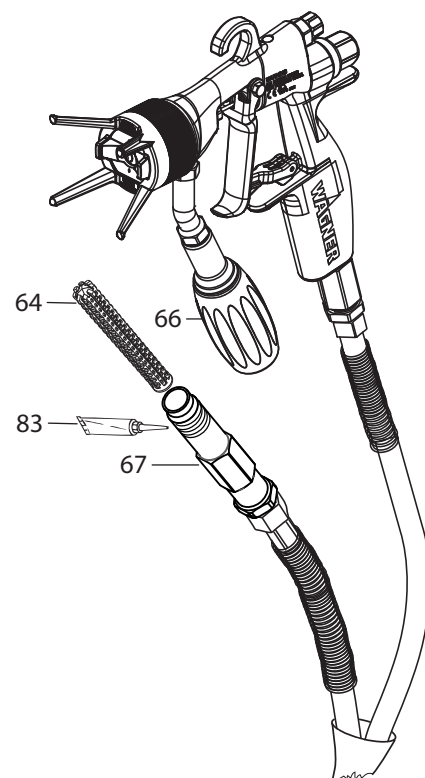

Procedure if connection is difficult to loosen:

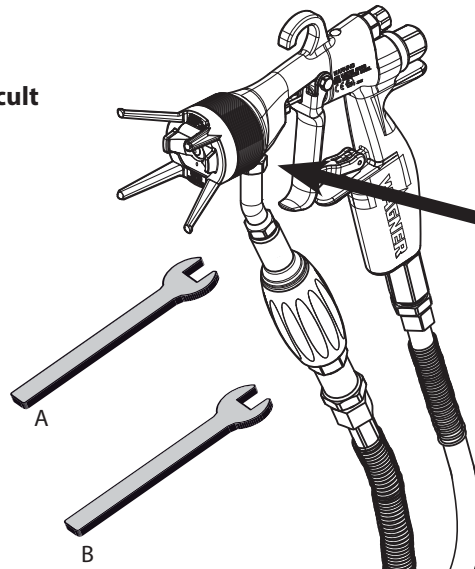

Loosen filter housing (67) with wrench size B open-end wrench, supporting the filter connection with size A open-end wrench.



Note:
Do not unscrew the filter connection.
The filter connection should be replaced in accordance with Chapter 10.8.

Wrench A Wrench size	Wrench B Wrench size
13 mm 0.51 inch	17 mm 0.67 inch

9 TROUBLE SHOOTING AND RECTIFICATION

	 DANGER
	<p>Incorrect maintenance/repair! Danger to life and equipment damage.</p> <ul style="list-style-type: none"> → Only a WAGNER service center or a suitably trained person may carry out repairs and replace parts. → Only repair and replace parts that are listed in the "Spare parts" chapter and that are assigned to the unit. → Before all work on the device and in the event of work interruptions: <ul style="list-style-type: none"> - Switch off the energy supply and the compressed air supply. - Relieve the pressure from the spray gun and device. - Secure the spray gun against actuation. → Observe the operating and service manual for all work.

Functional fault	Cause	Remedy	See Chapter
Insufficient product output.	Nozzle too small.	Select larger nozzle.	13
	Product pressure too low.	Increase product pressure.	
	Gun filter or high-pressure filter clogged at pump	Clean or replace filter.	8.4
	Nozzle is clogged.	Nozzle cleaning	7.3.6
	The valve rod path is too short.	Replace the valve rod.	10.4
Poor spray pattern	Atomizing air incorrectly adjusted.	Readjust the atomizing air.	7.3.1
	Nozzle worn.	Replace nozzle.	7.3.4
	Product pressure too low.	Increase the product pressure at pump.	
	The product viscosity is too high.	Dilute the spray product in accordance with the manufacturer's instructions.	
	The nozzle is partially clogged.	Nozzle cleaning	7.3.5 / 7.3.6
	The drilled holes in the air cap are damaged or clogged.	Clean or replace the air cap.	7.3.6
	Incorrectly selected air cap.	Insert the correct air cap (solvent/water based paint).	7.3.6 / 13.2

Valve rod leaks (paint path or air path)	The seals on the valve rod are damaged or the valve rod itself is damaged.	Replace the entire valve rod or the individual seals.	10.4
	Air valve seals are leaky.	Replace the air valve seal.	10.6
	Pretension is too low.	Tighten up the sealing screw.	
Gun will not shut off correctly	The valve seat or the valve ball is damaged.	Replace the parts.	10.4
	Pretension of the seals is too strong.	Replace the seals.	10.4 - 10.7

10 REPAIR WORK

10.1 REPAIR STAFF

Repair work should be undertaken carefully by qualified and trained personnel. They should be informed of specific hazards during their training.

The following hazards may arise during repair work:

- Health hazard from inhaling solvent vapors
- Use of unsuitable tools and aids

A skilled person must check to ensure that the device is in a reliable state after it is repaired.

10.2 SAFETY INSTRUCTIONS

→ Observe the safety instructions in Chapter 4 and Chapter 8.1.2.

Before a Repair

- Flush and clean the system. → Chapter 8.1.3.

After a Repair

- Carry out a safety checks in accordance with Chapter 8.2.3.
- Put the system into operation and check for leaks as described in Chapter 6.8.
- Function test in accordance with Chapter 11.

→ In accordance with the guideline for liquid ejection devices (ZH 1/406 and BGR 500 Part 2 Chapter 2.29 and Chapter 2.36):

- The liquid ejection devices should be checked by an expert (e.g., WAGNER service technician) for their safe working conditions as required and at least every 12 months.
- For shut down devices, the examination can be suspended until the next start-up.



DANGER

Incorrect maintenance/repair!

Danger to life and equipment damage.

- Only a WAGNER service center or a suitably trained person may carry out repairs and replace parts.
- Only repair and replace parts that are listed in the "Spare parts" chapter and that are assigned to the unit.
- Before all work on the device and in the event of work interruptions:
 - Switch off the energy supply and the compressed air supply.
 - Relieve the pressure from the spray gun and device.
 - Secure the spray gun against actuation.
- Observe the operating and service manual for all work.

10.3 DISMANTLING OF THE GUN

The following tools are required for carrying out the repair work on the gun described below:

- Open-end wrench SW 5
- Open-end wrench SW 6
- Open-end wrench SW 7
- Open-end wrench SW 13
- Open-end wrench SW 15
- Socket wrench SW 13
- Socket wrench SW 15
- Mounting key Order No. 179989
- Nozzle wrench, complete Order No. 128901
- Torque wrench 12±1 Nm; 8.85 lbft
- Pipe wrench
- Pin Ø 1.5 mm

Assembly aids:

Order No.	Quantity	Designation	Smaller tanks
9992831	1 pc = 50 ml	Loctite [®] 542	
9992833	1 pc = 250 ml	Loctite [®] 638 green	
9992590	1 pc = 50 ml	Loctite [®] 222	
9992698	1 pc = 200 g	Vaseline white PHHV II	
9992616	1 pc = 1 kg can	Molykote [®] DX grease	50 g tube = Order No. 2355419

Brand notice:

The brands specified in this document are property of the respective owners. Loctite[®], for example, is a registered brand of Henkel.

10.4 REPLACING PARTS ON THE VALVE ROD

10.4.1 DISASSEMBLING

1. Relieve pressure from the gun and from the device in accordance with Chapter 7.3.3.
2. Clean and decommission in accordance with Chapter 8.1.3.
3. Secure the gun with the locking device.
4. Unscrew the spring cap (5) using a size 15 mm; 0.59 inch socket wrench and remove the pressure springs (2) and (3).
5. Loosen the screw (22) and remove together with the nut (20).
6. Remove the trigger (21).
7. Loosen the sealing screw (10) using a size 7 mm; 0.28 inch single open-end wrench.
8. Carefully pull the valve rod unit (B), together with sealing screw (10), rearwards out of the gun housing (A).
9. Hold the clamping sleeve (4) with a size 6 mm; 0.24 inch open-end wrench and loosen collet chuck (18) with a size 5 mm; 0.20 inch open-end wrench.
10. Carefully pull valve rod (34) out forwards. Replace relevant parts.

NOTICE

Unsuitable tool!

Damage to seals and sealing surfaces.

→ Do not hold the valve rod with pliers or a similar tool.

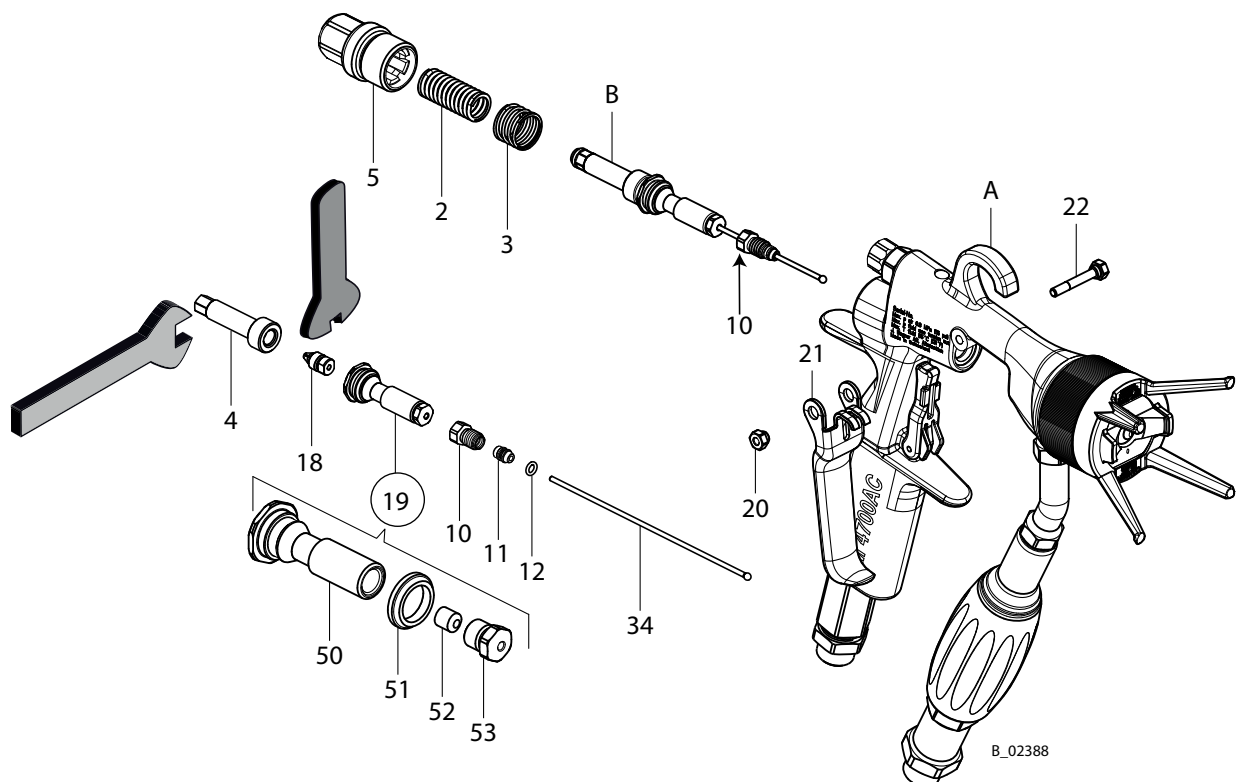

B_02388

10.4.2 REPLACING VALVE TAPPET SEALS

1. Hold valve tappet (50) in place with size 13 mm; 0.51 inch open-end wrench on and unscrew cover (53) with a size 7 mm; 0.28 inch single open-end wrench.
2. Remove the air valve seal (51) and seal (52) and replace with new seals. A special tool (order number 179989) is necessary for the assembly of the air valve seal (51).
3. Screw the valve tappet (50) and cover (53) together by hand. Carefully tighten in small increments with a 7 mm; 0.28 inch and 13 mm; 0.51 inch open-end wrench until a slight resistance is perceptible when moving the valve rod (34) in the valve tappet.

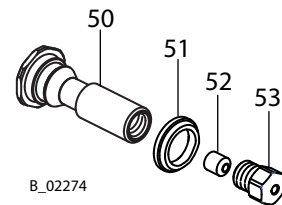
**Note:**

The seal (52) can be pulled out of the cover (53) with the help of an eye bolt.

10.4.3 REPLACING THE ROD SEAL

1. Carefully pull the rod seal (35) out of the gun housing.
2. Clean sealing surfaces in the gun housing.
3. Fit the new rod seal (35) to the rod seal tool (84).

Note:

Note the installation position of the rod seal (35).

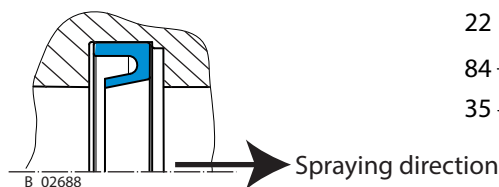

4. Insert the rod seal tool (84) together with the rod seal (35) into the drilled hole.
5. Fit the trigger (21) with screw (22) to the gun and
6. carefully push the tool with rod seal (35) over the trigger (21) into the recess in the housing.
7. Remove the trigger (21), screw (22) and rod seal tool (84).

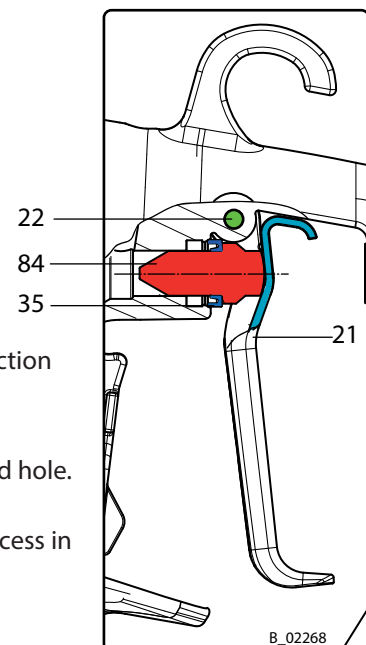

10.4.4 ASSEMBLING

1. Attach the sealing collar (11) to the valve rod (34) together with the inserted O-ring (12) and sealing screw (10).
2. Push the completely assembled valve tappet (19) onto the valve rod (34).
3. Screw the collet chuck (18) into the clamping sleeve (4) (do not tighten).
4. Insert the preassembled valve rod into the preassembled clamping sleeve (4 and 18) up to the button stop.
5. Hold the clamping sleeve (4) with size 6 mm; 0.24 inch wrench in position, screw the preassembled valve rod to the clamping sleeve and tighten with a size 5 mm; 0.20 inch open-end wrench, tightening torque 5 ± 1 Nm; 3.69 lbft. Note reference dimension.
6. Carefully insert the complete valve rod (B) into the gun housing.
7. Screw in the sealing screw (10) but do not tighten yet.
8. Position the trigger (21) and fasten with screw (22) and nut (20).
9. Insert the pressure springs (3) and (2) and screw on the spring cap (5), tightening torque 8 ± 1 Nm; 5.9 lbft.
10. Carefully tighten the sealing collar (11, 12) over the sealing screw (10). Ensure that the trigger runs smoothly.
11. Commissioning in accordance with Chapter 6.8.

Note:

Only use silicone and resin-free grease.

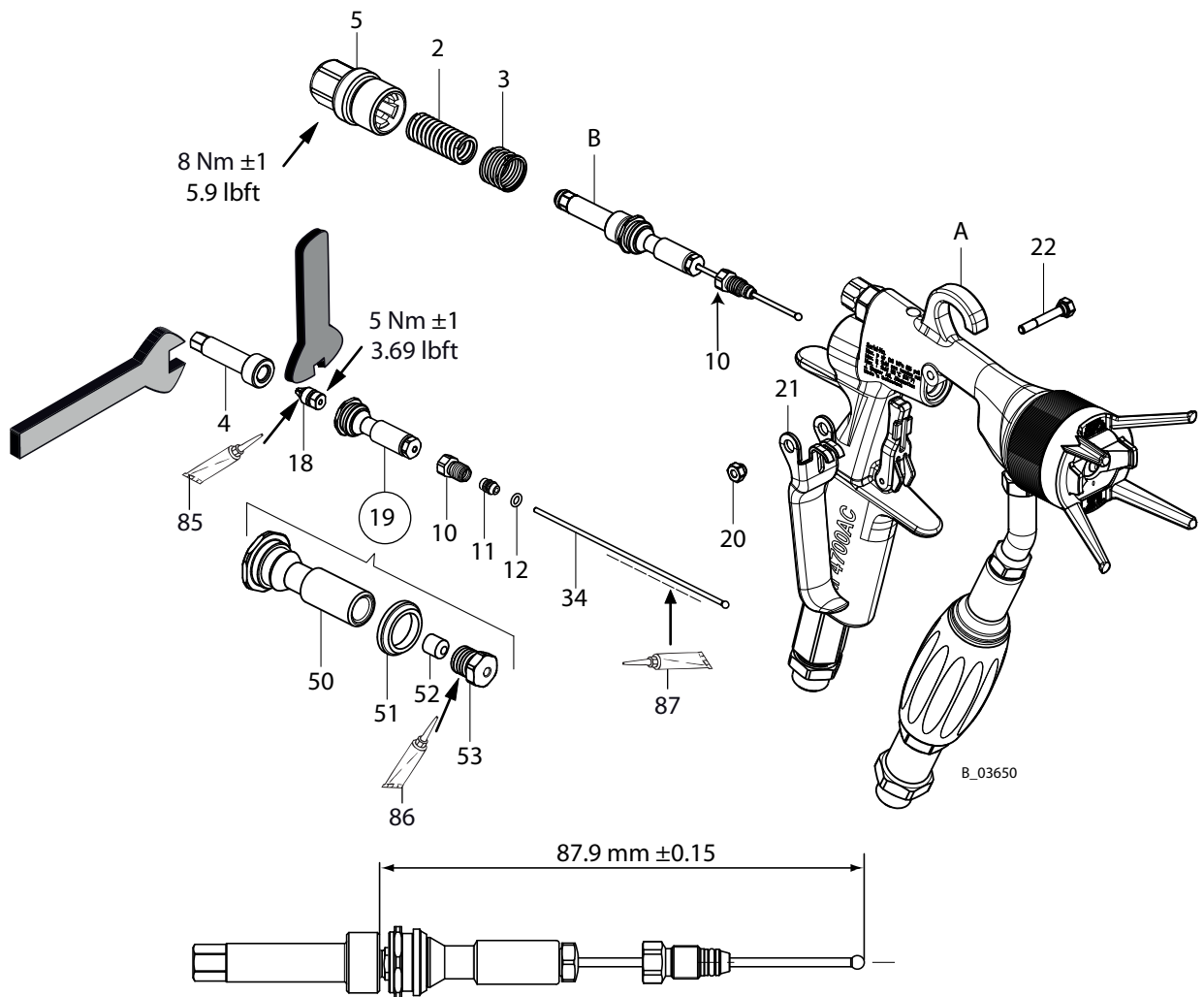

10.5 REPLACING THE NOZZLE SEAL

NOTICE

Defective nozzle seal!

Product sprays into the air cap next to the nozzle.

Risk of contamination.

- Do not clean the nozzle seal with sharp-edged objects.
- Replace the nozzle seal if the sealing surface is damaged.

1. Relieve pressure from the gun and from the device in accordance with Chapter 7.3.3.
2. Clean and decommission in accordance with Chapter 8.1.3.
3. Secure the gun with the locking device.
4. Unscrew the union nut with nozzle guard (33).
5. Remove the air cap (36) together with the nozzle (13).
6. Carefully release the nozzle seal (17) with the help of a screwdriver.
7. Attach the new nozzle seal to the valve housing (16).
8. Complete the gun according to Chapter 7.3.4.

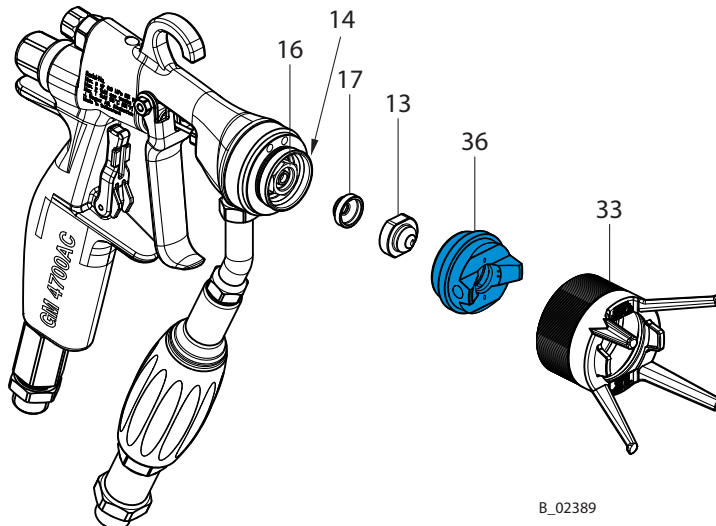

10.6 REPLACING THE "AIR" SEALING RING**NOTICE****Shaping air and atomizer air not separate!**

Poor spray pattern.

Spray jet cannot be adjusted.

→ Treat the distributor seal (F) with care.

1. Relieve pressure from the gun and from the device in accordance with Chapter 7.3.3.
2. Clean and decommission in accordance with Chapter 8.1.3.
3. Secure the gun with the locking device.
4. Unscrew the union nut with nozzle guard (33).
5. Remove the air cap (36) together with the nozzle (13).
6. Remove the defective sealing ring (14/F) with the help of pipe tongs or with a large screwdriver.
7. **Assembly:** Plug the new sealing ring (14/F) onto the air cap (36).
8. Place the air cap, together with sealing ring (14/F), into the gun body.
9. Attach the union nut (33) and screw it in until the sealing ring snaps into place in the mounting groove (audible snap).
10. Demount the union nut (33) and air cap (36) and complete the spray gun according to Chapter 7.3.4.

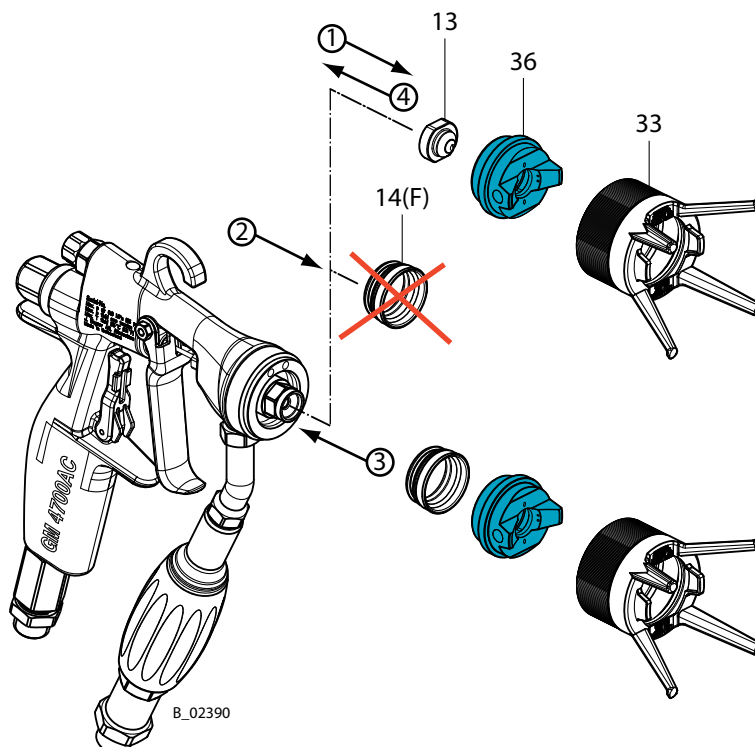

10.7 REPLACING THE SEALING FITTING OF THE ROUND JET NOZZLE

NOTICE
<p>Defective nozzle body! Poor spray pattern. → Handle the nozzle body (A) with care.</p>

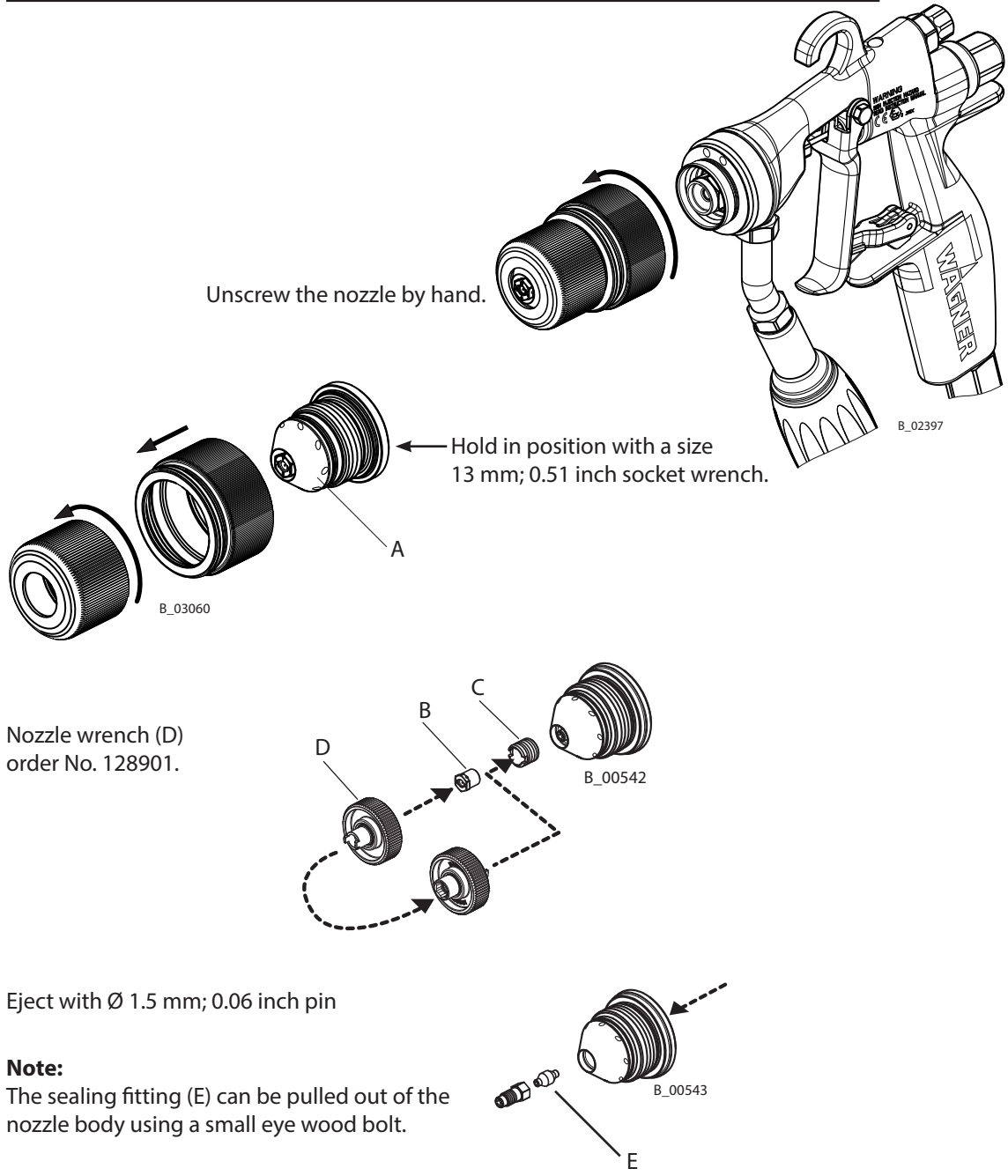

10.8 REPLACING THE SPRING CAP

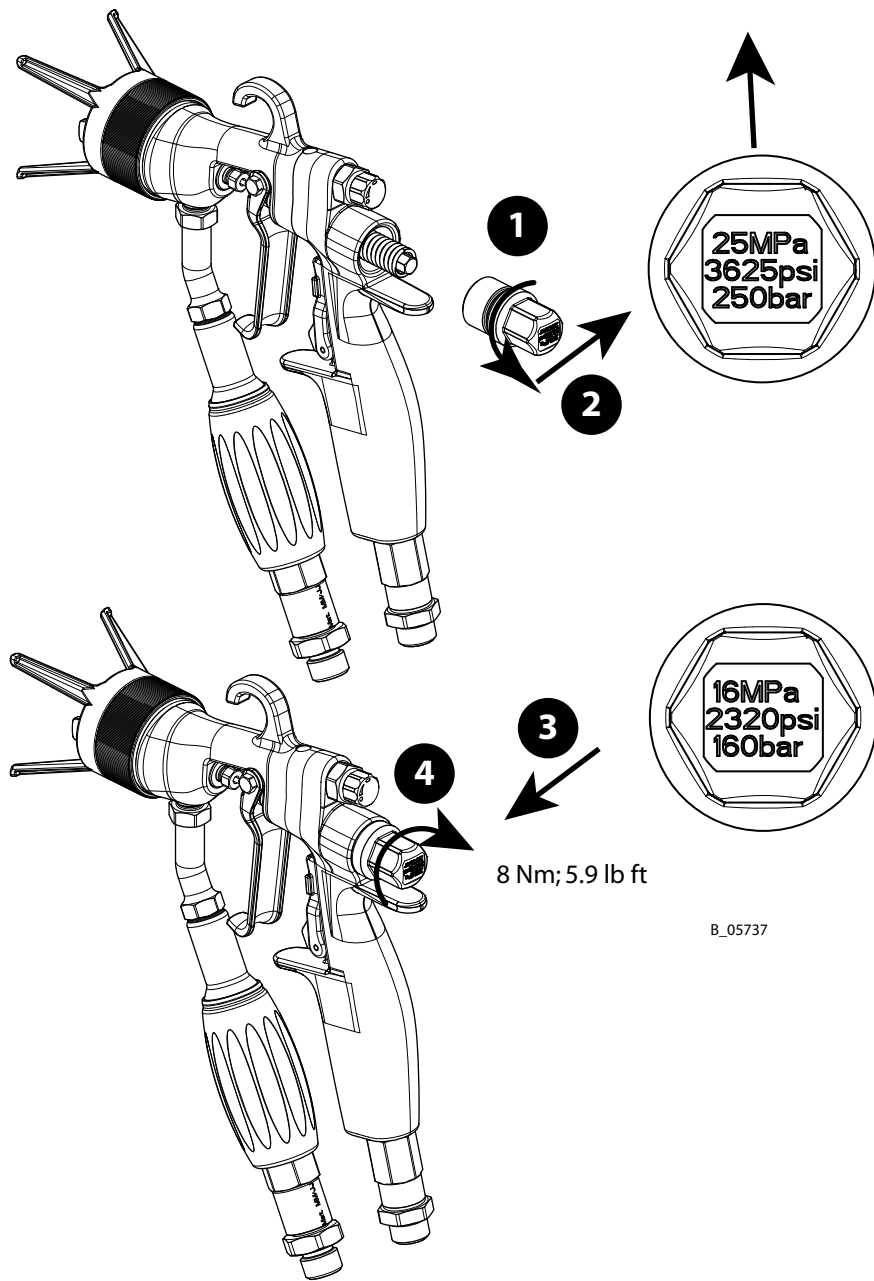



B_05737

10.9 REPLACE FILTER CONNECTION (ONLY GM 4700AC)**10.9.1 REQUIRED TOOLS AND AIDS**

The following tools are required for carrying out the repair work on the gun described below:

- Filter connection GM 4700AC, complete Order No. 2320114
- Open-end wrench size SW 13; 0.51 inch
- Loctite [®] 638
- Hot-air gun
- Suitable oven for curing the adhesive

10.9.2 SAFETY INSTRUCTIONS

	 WARNING
	<p>Incompatibility of cleaning agent and working medium! Risk of explosion and danger of poisoning by toxic gases.</p> <p>→ Examine the compatibility of the cleaning agents and working media on the basis of the safety data sheets.</p>

10.9.3 DISASSEMBLY

1. Dismount all movable and heat-sensitive (positions X) of the spray gun.
2. Use the air gun to heat the area around the hollow screw to approx. 150 °C; 302 °F.

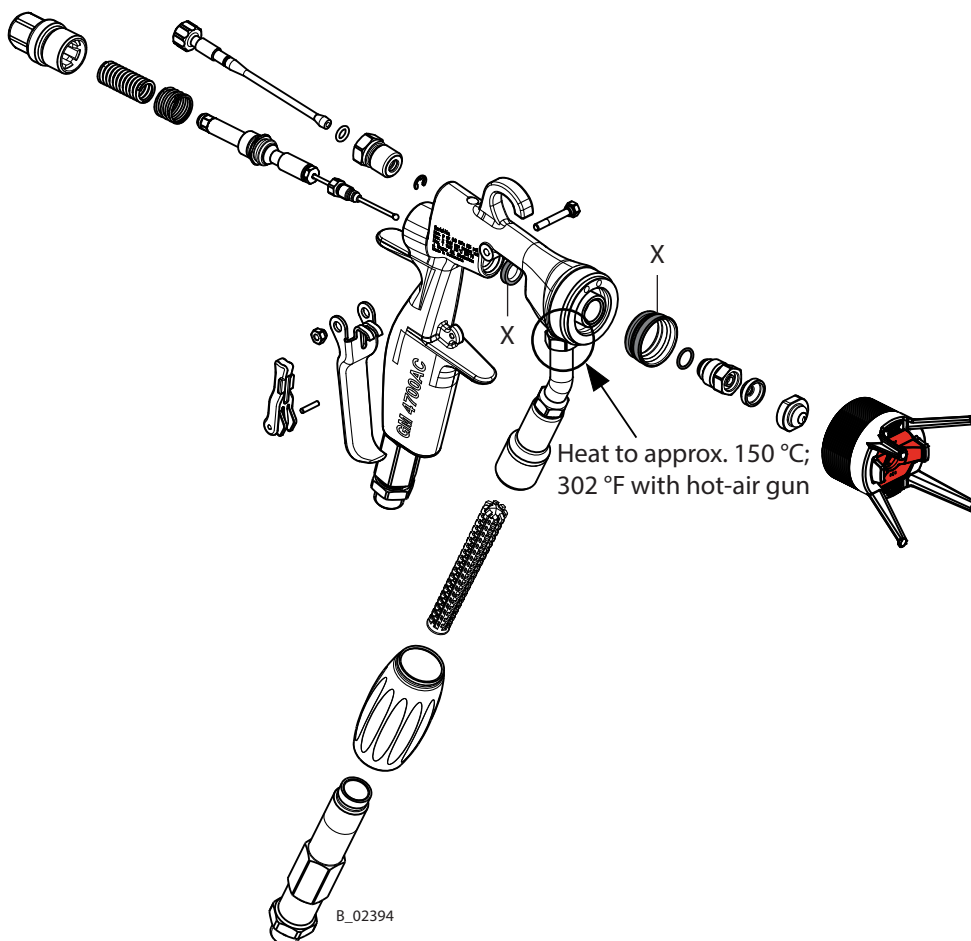

	<p>! WARNING</p>
	<p>Hot gun housing! Burns.</p>
	<p>→ Wear protective gloves when dismantling the filter connection.</p>

3. Loosen the hollow screw with a size SW13; 0.51 inches open-end wrench, then remove the filter connection.
4. Thoroughly clean all re-usable parts with a suitable solvent.



10.9.4 ASSEMBLING

1. Apply the Loctite[®] 638 to the thread and between the hollow screw and filter connection.
2. Put the filter connection into the gun connection, align and tighten the hollow screw with a tightening torque of 15 Nm; 11 lbft.
Exceeding the allowable torque will damage the filter connection.
3. Harden the adhesion point in the housing in a oven at 40 °C; 104 °F for at least 30 minutes.

	 WARNING
	<p>Defective parts! Leakage caused by defective parts. The resulting spray jet can inject product into your body (skin, eyes, etc.).</p> <ul style="list-style-type: none"> → Always replace defective parts, o-rings and seal sets. → Ensure that adhesion points are clean and grease-free. → Do not exceed the specified torque of 15 Nm; 11 lbft!

4. After cooling off, completely assemble the spray gun. In doing so, note the assembly information in the spare part drawing in Chapter 14.2 of the operating manual.
5. Use a suitable medium to check the spray gun for leaks at 25 MPa; 250 bar; 3626 psi or 16 MPa; 160 bar; 2320 psi.

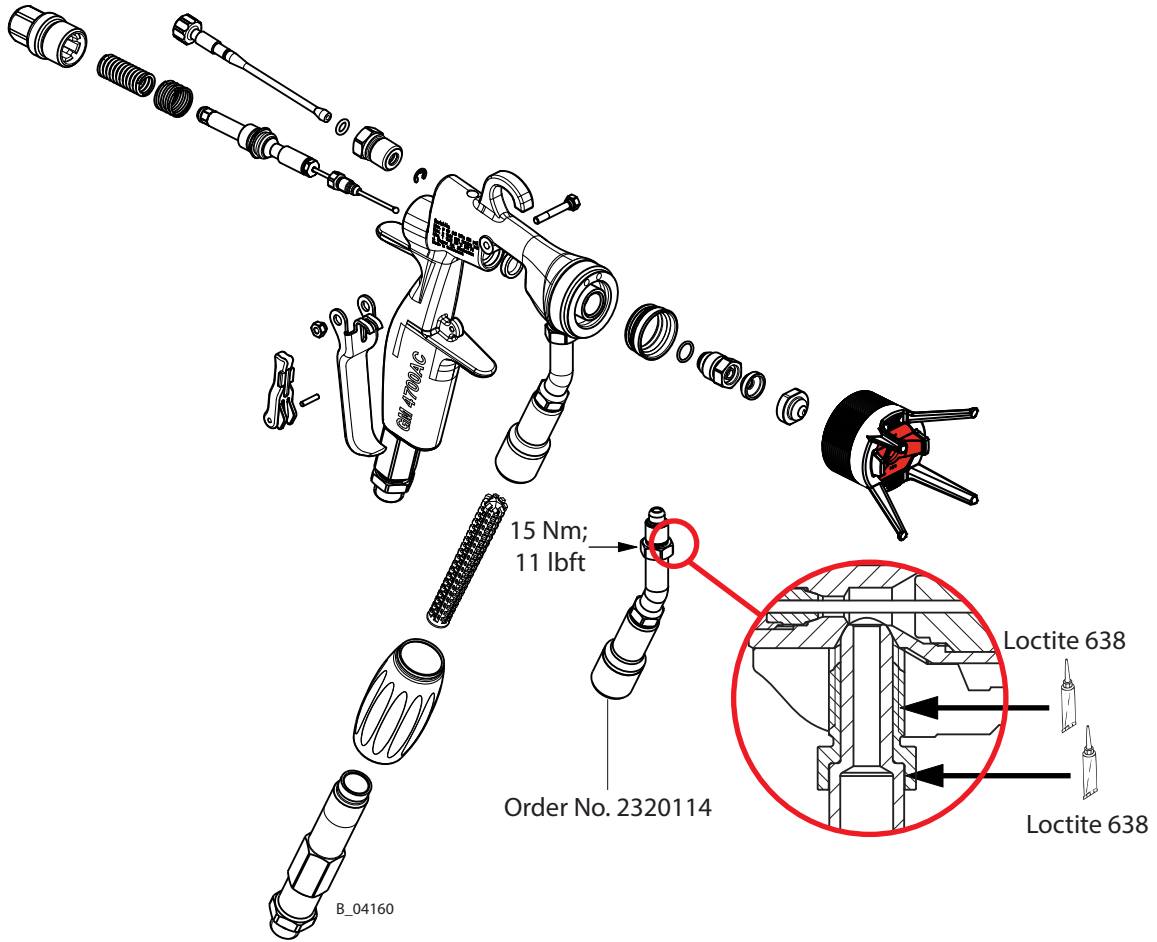

11 FUNCTION TEST AFTER THE REPAIR

After all repairs, the gun must be checked for safe condition before recommissioning. The necessary scope of inspection and testing depends on the repair carried out and must be documented by the repair staff.

Assembly inspection	
Activities	Aid tools
<p>1. Leak test</p> <ul style="list-style-type: none"> - Connect 1 bar; 0.1 MPa; 14.50 psi and 8 bar; 0.8 MPa; 116 psi air pressure to the air connection and product connection. <p>Place the gun completely into the water bath and check all sealing points with 1 bar; 0.1 MPa; 14.50 psi and 8 bar; 0.8 MPa; 116 psi for leaks. At 8 bar; 0.8 MPa; 116 psi bar, the gun must be completely sealed. At 1 bar; 0.1 MPa; 14.50 psi, a slight leak can be tolerated: 5 air bubbles per minute.</p>	<p>Air connection 1 bar / 8 bar</p> <p>Water bath</p>
Injection and final inspection	
Activities	Aid tools
<p>2. Trigger lever function test</p> <ul style="list-style-type: none"> - The trigger lever must be pulled as far as it will go. Make sure that the trigger lever can move slightly in its rest position. - Put the trigger lever locking device into the locking position, configure the air product pressure, and pull the trigger lever. Neither air nor product may leak or escape. - Check that the trigger lever locking device is not reset by the trigger lever when pulling in the locking position. 	<p>Manual inspection</p>
<p>3. Leak test</p> <ul style="list-style-type: none"> - Attach the gun, slowly increase the product pressure in increments using a suitable medium until the maximum pressure (250 bar, 25 MPa; 3625 psi or 160 bar, 16 MPa; 2320 psi) specified on the type plate is reached. - Trigger and flush the gun multiple times. - Make sure that: <ul style="list-style-type: none"> - Is the product connection sealed when the gun is closed? - Is the product valve sealed? - No product discharge at the valve rod seal? <p>If product leaks, tighten the sealing screw: The sealing screw on the valve rod must be tightened. Tighten the sealing screw with the open-end wrench if necessary. (In doing so, it is important to make sure that the valve rod still runs smoothly and the gun closes reliably).</p>	<p>Visual inspection</p> <p>The 160 bar variant is inspected at 160 bar.</p> <p>250 bar or 160 bar product connection</p> <p>Atomizing air 3 bar</p> <p>Open-end wrench size SW 7 mm for the sealing screw</p>

Activities	Aid tools
<p>4. Checking the switching sequence</p> <ul style="list-style-type: none"> - Attach the AC nozzle and air cap. - Set the injection pressure to 100 bar; 10 MPa; 1450.40 psi, pull the trigger slowly, note the switching sequence "switch on" and "switch off". <p>Switch on: atomizing air / shaping air on, product on Switch off: product off, atomizing air / shaping air off</p>	Visual inspection
<p>5. Flushing the gun</p> <ul style="list-style-type: none"> - Switch off the air and product supply, open flushing valve, pull trigger lever and flush gun or blow out with air. <p>Flush the gun without the valve and air cap. In doing so, you can remove the air connection hose.</p> <ul style="list-style-type: none"> - Close the flushing valve; when almost no product is escaping any longer, remove the product connection hose and blow the rest of the test medium out of the gun using an air gun. 	

12 DISPOSAL

When the equipment must be scrapped, please differentiate the disposal of the waste materials.
The following materials have been used:

- Stainless steel
- Aluminum
- Elastomers
- Plastic
- Carbide

The consumable products (lacquers, adhesives, solvents) must be disposed of in accordance with the applicable specific standards.

13 ACCESSORIES

13.1 ROUND JET NOZZLE CAP

Order No.	Designation
394180	Round jet nozzle cap (without nozzle insert)

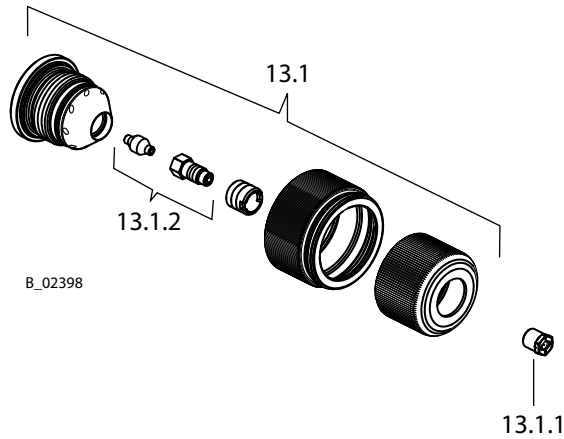

13.1.1 NOZZLE INSERTS RXX

Order No.	Designation	Marking	Volumetric flow rate*	Jet Ø**
132720	Nozzle insert R11	11	0.16; 160	approx. 250; 9.84
132721	Nozzle insert R12	12	0.22; 220	approx. 250; 9.84
132722	Nozzle insert R13	13	0.27; 270	approx. 250; 9.84
132723	Nozzle insert R14	14	0.34; 340	approx. 250; 9.84
132724	Nozzle insert R15	15	0.38; 380	approx. 250; 9.84
132725	Nozzle insert R16	16	0.43; 430	approx. 250; 9.84
132726	Nozzle insert R17	17	0.48; 480	approx. 250; 9.84
132727	Nozzle insert R18	18	0.53; 530	approx. 250; 9.84
132728	Nozzle insert R19	19	0.59; 590	approx. 250; 9.84
132729	Nozzle insert R20	20	0.65; 650	approx. 250; 9.84
132730	Nozzle insert R21	21	0.71; 710	approx. 250; 9.84
132731	Nozzle insert R22	22	0.77; 770	approx. 250; 9.84

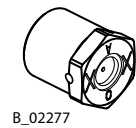

* Volumetric flow in l/min; cc/min water at 10 MPa; 100 bar; 1450 psi

** Jet Ø in mm; inches at a distance of approx. 30 cm; 11.8 inches from the object and at a pressure of 10 MPa; 100 bar; 1450 psi, synthetic resin paint, 20 DIN 4 seconds.

13.1.2 COMPLETE NOZZLE SCREW JOINT

Order No.	Designation
132922	Nozzle screw joint, complete

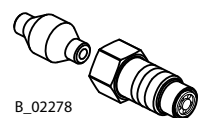

13.2 AIR CAPS

Order No.	Designation
2313494	Air cap LV plus (red) for low viscosity products
2313497	Air cap HV plus (blue) for high viscosity products
2313498	Air cap LA plus (bronze)

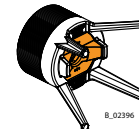
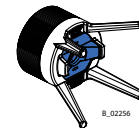
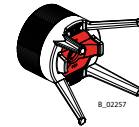

13.3 ANODIZED UNION NUT

Order No.	Designation
2330340	Completely anodized union nut (without air cap) suitable for processing water-based paints

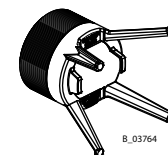



13.4 AIRCOAT NOZZLES ACF3000

Article No. 379xxx

In order to determine the article number of a nozzle, please select the number from the table and replace the three xxx.
Example: nozzle 411 -> article number 379411



Size	Spray angle						
	10°	20°	30°	40°	50°	60°	80°
07	107	207		407			
09		209	309	409	509	609	
11	111	211	311	411	511	611	811
13	113	213	313	413	513	613	813
15	115	215	315	415	515	615	815
17		217	317	417	517	617	817
19		219	319	419	519	619	819
21		221		421	521	621	821
23				423		623	823

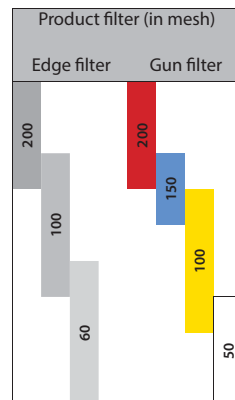

Drilled hole	Material flow*
inch (mm)	l/min (gal/min)
0,007 (0,18)	0,23 (0,061)
0,009 (0,23)	0,26 (0,069)
0,011 (0,28)	0,38 (0,100)
0,013 (0,33)	0,55 (0,145)
0,015 (0,38)	0,75 (0,198)
0,017 (0,43)	0,96 (0,254)
0,019 (0,48)	1,20 (0,317)
0,021 (0,53)	1,45 (0,383)
0,023 (0,58)	1,79 (0,473)

B_02399

55	100	145	195	250	300	400
(2,17)	(3,94)	(5,71)	(7,68)	(9,84)	(11,81)	(15,75)
∅ Spray pattern width mm (inch)**						

* Tested with water and 100 bar pressure.

** Tested with 110 bar (1595 psi), 30 cm (11.81 inches) distance and lacquer 56DIN-4s.

13.5 AIRCOAT PRE-ATOMIZER NOZZLES ACF3000 PLUS

Article No. 321xxx

In order to determine the article number of a nozzle, please select the number from the table and replace the three xxx.
Example: nozzle 410 -> article number 321410



Size	Spray angle				
	20°	30°	40°	50°	60°
08	208	308	408	508	
10	210	310	410	510	610
12	212	312	412	512	612
14	214	314	414	514	614
16	216	316	416	516	616
18	218	318	418	518	618
20		320	420		620
22			422		622

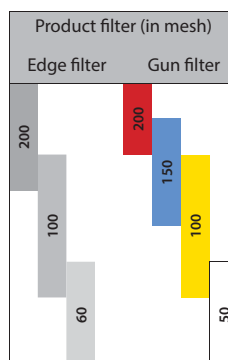

Drilled hole	Product flow*
inch (mm)	l/min (gal/min)
0,008 (0,20)	0,22 (0,058)
0,010 (0,25)	0,32 (0,084)
0,012 (0,30)	0,44 (0,116)
0,014 (0,36)	0,60 (0,159)
0,016 (0,41)	0,76 (0,201)
0,018 (0,46)	0,92 (0,244)
0,020 (0,51)	0,11 (0,030)
0,022 (0,56)	0,14 (0,036)

B_05736

100	145	195	250	300
(3,94)	(5,71)	(7,68)	(9,84)	(11,81)
∅ Spray pattern width mm (inch)**				

* Tested with water and 100 bar pressure.

** Tested with 110 bar (1595 psi), 30 cm (11.81 inches) distance and lacquer 56DIN-4s.

13.6 FILTER INSERT

Order No. for 10 pieces	Filter sizes	Mesh	Use for nozzles
2315723	Filter insert, red	200	0.007" - 0.011"
2315724	Filter insert, blue	150	0.011" - 0.013"
2315725	Filter insert, yellow	100	0.013" - 0.019"
2315726	Filter insert, white	50	0.019" - 0.023"

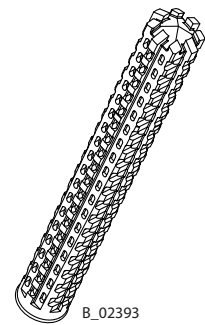

13.7 SWIVEL JOINTS

Order No.	Designation
394933	Swivel joint set for product (NPSM 1/4") and air hose connection (G1/4")
394928	Swivel joint for product connection (NPSM 1/4")
364938	Swivel joint for air connection G1/4"

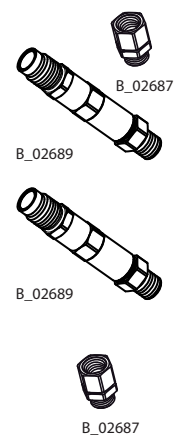

13.8 HOSES

Order No.	Designation (All AC hose sets consist of a section each of product, air and protective hose)
2309705	AC hose set DN3 PN270 1/4"NPS 7.5 m PA T Product: 1/4"NPS, 7.5 m; 24.6 ft, DN 3; ID 0.12 inch, 27 MPa; 270 bar; 3916 psi Air: G1/4", 7.5 m; 24.6 ft, DN 6 mm; ID 0.24 inch, 1 MPa, 10 bar; 145 psi
2309706	AC hose set DN4 PN270 1/4"NPS 7.5 m PA T Product: 1/4"NPS, 7.5 m; 24.6 ft, DN 4; ID 0.16 inch, 27 MPa; 270 bar; 3916 psi Air: G1/4", 7.5 m; 24.6 ft, DN 6 mm; ID 0.24 inch, 1 MPa, 10 bar; 145 psi
2312801	AC hose set DN4 PN270 1/4"NPS 10.0 m PA T Product: 1/4"NPS, 10 m; 32.8 ft, DN 4; ID 0.16 inch, 27 MPa; 270 bar; 3916 psi Air: G1/4", 10 m; 32.8 ft, DN 6 mm; ID 0.24 inch, 1 MPa, 10 bar; 145 psi
2309634	AC hose set DN4 PN270 1/4"NPS 15.0 m PA T Product: 1/4"NPS, 15 m; 49.2 ft, DN 4; ID 0.16 inch, 27 MPa; 270 bar; 3916 psi Air: G1/4", 15 m; 49.2 ft, DN 6 mm; ID 0.24 inch, 1 MPa, 10 bar; 145 psi
2309635	AC hose set DN4 PN270 1/4"NPS 20.0 m PA T Product: 1/4"NPS, 20 m; 65.6 ft, DN 4; ID 0.16 inch, 27 MPa; 270 bar; 3916 psi Air: G1/4", 20 m; 65.6 ft, DN 6 mm; ID 0.24 inch, 1 MPa, 10 bar; 145 psi
2322656	AC hose set DN3 PN270 1/4"NPS 3.0 m PA T Product: 1/4"NPS, 3 m; 9.84 ft, DN 3; ID 0.12 inch, 27 MPa; 270 bar; 3916 psi Air: G1/4", 3 m; 9.84 ft, DN 6 mm; ID 0.24 inch, 1 MPa, 10 bar; 145 psi
3676437	Protective hose

13.9 NOZZLE EXTENSIONS

Order No.	Designation
394090	Nozzle extension AC 300
394091	Nozzle extension AC 600

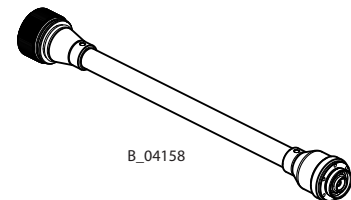

13.10 MISCELLANEOUS

Order No.	Designation
9997001	Nozzle cleaning brush
394941	Service set GM 4600/GM 4700AC
367560	Double connector NPSM1/4" (external thread), for product hose extension
9985720	Double nipple G1/4" (external thread), for air hose extension
2324747	Sealing collar UHMW-PE, complete, suitable for 2K-PU paints

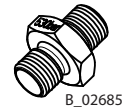

14 SPARE PARTS

14.1 HOW CAN SPARE PARTS BE ORDERED?

Always supply the following information to ensure delivery of the right spare part:

Order number, designation and quantity

The quantity need not be the same as the number given in the quantity column "Stk" on the list. This number merely indicates how many of the respective parts are used in each component.

The following information is also required to ensure smooth processing of your order:

- Address for the invoice
- Address for delivery
- Name of the person to be contacted in the event of any queries
- Type of delivery (normal mail, express delivery, air freight, courier, etc.)

Identification in spare parts lists.

Explanation of column "K" (labeling) in the following spare parts lists:

- ◆ Wearing parts

Note: These parts are not covered by warranty terms.

- Not part of standard equipment, available, however, as additional extra.



DANGER

Incorrect maintenance/repair!

Danger to life and equipment damage.

- Only a WAGNER service center or a suitably trained person may carry out repairs and replace parts.
- Only repair and replace parts that are listed in the "Spare parts" chapter and that are assigned to the unit.
- Before all work on the device and in the event of work interruptions:
 - Switch off the energy supply and the compressed air supply.
 - Relieve the pressure from the spray gun and device.
 - Secure the spray gun against actuation.
- Observe the operating and service manual for all work.

14.2 SPARE PARTS GM 4700AC

Spare parts lists GM 4700AC

Pos	K	Stk	Order No.	Designation
1		1	2313585	GM 4700AC 25 MPa NPSM1/4"
2		1	9999501	Helical spring on the product side
3		1	9999500	Helical spring on the air side
4		1	2312140	Tension sleeve
5		1	394335	Spring cap 16 MPa; 160 bar; 2320 psi
5		1	394333	Spring cap 25 MPa; 250 bar; 3625 psi
6	◆	1	394924	Air tappet, complete
8	◆	1	2311320	Valve rod unit, complete
10		1	394327	Sealing screw
11	*◆	1	394328	Sealing collar
11	◆●	1	2324747	Sealing collar UHMW-PE, complete (including pos. 12)
12	*◆	1	9971445	O-ring
13	◆●	1	379xxx	AC nozzle (see Chapter 13.4)
13	◆●	1	321xxx	AC nozzle plus (see Chapter 13.5)
14	*◆	1	394339	Sealing ring
15	*◆	1	9974245	O-ring
16	*◆	1	394922	Valve housing, complete
17	*◆	1	394338	Nozzle seal
18		1	2312149	Collet chuck
19		1	394257	Valve tappet, complete
20		1	394318	Nut
21		1	394601	Trigger
22		1	394319	Screw
23		1	394334	Safety clip
24		1	9935088	Parallel pin
25		1	394313	Air tappet
26	*◆	1	9974243	O-ring
27		1	394303	Mounting bracket
28	*◆	1	9921906	Lock washer
29		1	2324766	Air swivel, complete
34	*◆	1	394920	Valve rod, complete
35	*◆	1	394323	Rod seal
36	◆●	1	2313494	Air cap LV plus (red)
36	◆●	1	2313497	Air cap HV plus (blue)
36	◆●	1	2313498	Air cap LA plus (bronze)
50		1	394309	Valve tappet
51	*◆	1	179338	Air valve seal
52	*◆	1	179395	Seal
53	*◆	1	394322	Cap
55	●	1	394336	Nozzle body

◆ = Wearing part

* = Included in service set

● = Not part of the standard equipment but available as a special accessory.

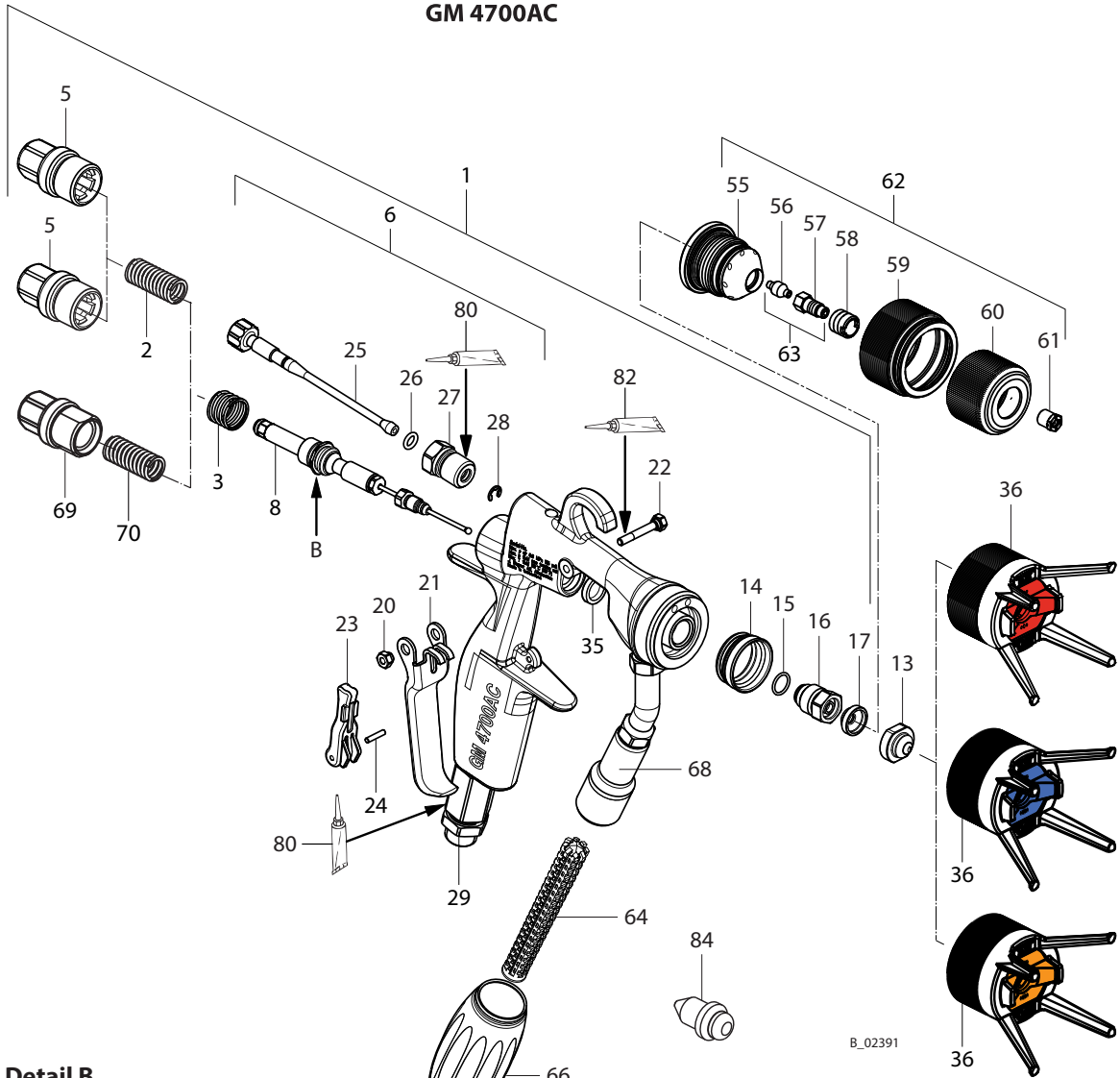

Detail B

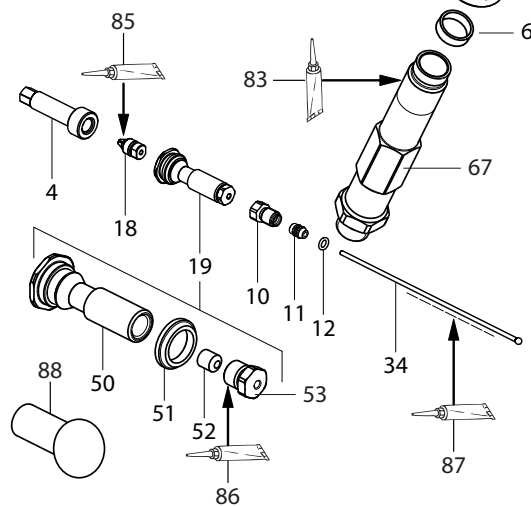

Mounting materials

Pos	K	Order No.	Designation
80	●	9992831	Loctite® 542
81	●	9992833	Loctite® 638 green
82	●	9992590	Loctite® 222
83	●	9992609	Anti-seize paste
84	★●	394342	Tool valve rod seal
85	●		Molykote® DX grease
86	●	9992528	Loctite® 270
87	●	9992698	Vaseline white PHHV II
88	●	179989	Tool air valve seal

Spare parts lists GM 4700AC

Pos	K	Stk	Order No.	Designation
56	◆●	1	128327	Sealing fitting
57	◆●	1	132516	Nozzle screw joint, complete
58	●	1	132351	Nozzle screwed connection holder
59	●	1	394308	Union nut
60	●	1	394337	Nozzle nut
61	◆●	1	132...	Nozzle insert R (various dimensions see Chapter 13.1.1)
62	●	1	394180	Round jet nozzle cap (see Chapter 13.1.)
63	◆●	1	132922	Nozzle screw joint, complete
64	◆	1	--	Filter insert, yellow (middle), 100 meshes per inch*
	◆●	1	2315723	*Filter insert, red (fine), 200 meshes per inch, 10 pieces
	◆●	1	2315724	*Filter insert, blue (middle), 150 meshes per inch, 10 pieces
	◆●	1	2315725	*Filter insert, yellow (middle), 100 meshes per inch, 10 pieces
	◆●	1	2315726	*Filter insert, white (coarse), 50 meshes per inch, 10 pieces
65	★◆	1	128389	Seal
66	◆	1	2311491	Turning handle
67		1	2320016	Filter housing, complete
68		1	2320114	Filter connection GM 4700AC, complete
69	●	1	2352651	Spring cap 35 MPa; 350 bar; 5076 psi
70	●	1	2353758	Pressure spring for spring cap 35 MPa; 350 bar; 5076 psi
	●	1	394941	Service set GM 4600/4700AC

◆ = Wearing part

★ = Included in service set

● = Not part of the standard equipment but available as a special accessory.

14.3 SPARE PARTS GM 4700AC-H

Spare parts list GM 4700AC-H

Pos	K	Stk	25 MPa	Designation
			Order No.	
1		1	2315700	GM 4700AC-H, 35 MPa NPSM1/4"
2		1	9999501	Helical spring on the product side
3		1	9999500	Helical spring on the air side
4		1	2312140	Tension sleeve
5		1	394333	Spring cap 25 MPa; 250 bar; 3625 psi
6	◆	1	394924	Air tappet, complete
8	◆	1	2311320	Valve rod unit, complete
10		1	394327	Sealing screw
11	★ ◆	1	394328	Sealing collar
11	◆ ●	1	2324747	Sealing collar UHMW-PE, complete (including pos. 12)
12	★ ◆	1	9971445	O-ring
13	◆ ●	1	379xxx	AC nozzle (see Chapter 13.4)
13	◆ ●	1	321xxx	AC nozzle plus (see Chapter 13.5)
14	★ ◆	1	394339	Sealing ring
15	★ ◆	1	9974245	O-ring
16	★ ◆	1	394922	Valve housing, complete
17	★ ◆	1	394338	Nozzle seal
18		1	2312149	Collet chuck
19		1	394257	Valve tappet, complete
20		1	394318	Nut
21		1	394601	Trigger
22		1	394319	Screw
23		1	394334	Safety clip
24		1	9935088	Parallel pin
25		1	394313	Air tappet
26	★ ◆	1	9974243	O-ring
27		1	394303	Mounting bracket
28	★ ◆	1	9921906	Lock washer
29		1	2324766	Air swivel, complete
34	★ ◆	1	394920	Valve rod, complete
35	★ ◆	1	394323	Rod seal
36	◆ ●	1	2313494	Air cap LV plus (red)
36	◆ ●	1	2313497	Air cap HV plus (blue)
36	◆ ●	1	2313498	Air cap LA plus (bronze)
50		1	394309	Valve tappet
51	★ ◆	1	179338	Air valve seal
52	★ ◆	1	179395	Seal
53	★ ◆	1	394322	Cap
55	●	1	394336	Nozzle body

◆ = Wearing part

★ = Included in service set

● = Not part of the standard equipment but available as a special accessory.

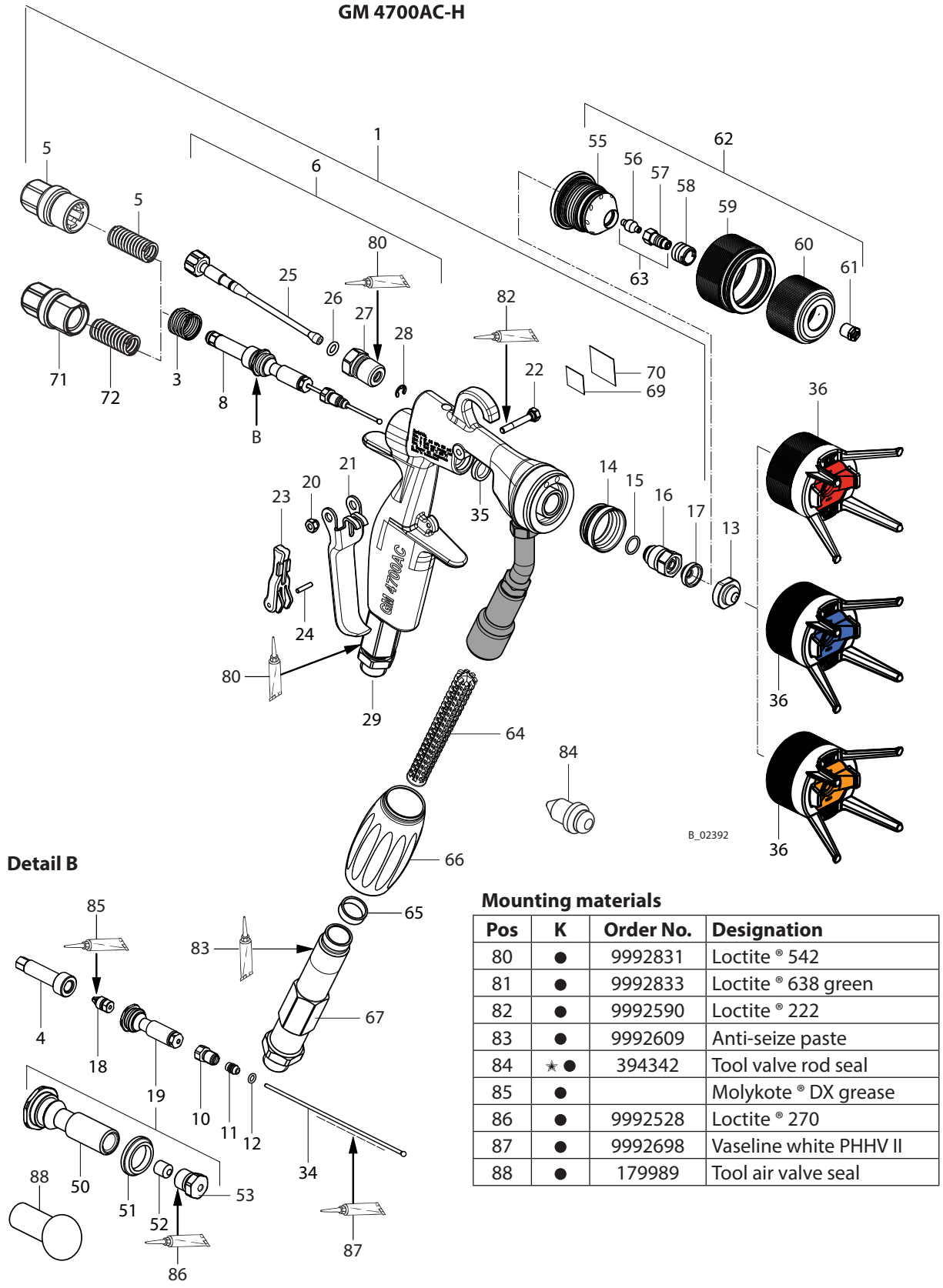

Spare parts list GM 4700AC-H

Pos	K	Stk	25 MPa	Designation
			Order No.	
56	◆ ●	1	128327	Sealing fitting
57	◆ ●	1	132516	Nozzle screw joint, complete
58	●	1	132351	Nozzle screwed connection holder
59	●	1	394308	Union nut
60	●	1	394337	Nozzle nut
61	◆ ●	1	132...	Nozzle insert R (various dimensions see Chapter 13.1.1)
62	●	1	394180	Round jet nozzle cap (see Chapter 13.1.)
63	◆ ●	1	132922	Nozzle screw joint, complete
64	◆	1	--	Filter insert, yellow (middle), 100 meshes per inch*
	◆ ●	1	2315723	*Filter insert, red (fine), 200 meshes per inch, 10 pieces
	◆ ●	1	2315724	*Filter insert, blue (middle), 150 meshes per inch, 10 pieces
	◆ ●	1	2315725	*Filter insert, yellow (middle), 100 meshes per inch, 10 pieces
	◆ ●	1	2315726	*Filter insert, white (coarse), 50 meshes per inch, 10 pieces
65	★ ◆	1	128389	Seal
66	★ ◆	1	2311491	Turning handle
67		1	2320016	Filter housing, complete
69	◆	1	9998910	Instruction label "hot surfaces"
70	◆	1	9998911	Protection label for 9998910
71	●	1	2352651	Spring cap 35 MPa; 350 bar; 5076 psi
72	●	1	2353758	Pressure spring for spring cap 35 MPa; 350 bar; 5076 psi
	●	1	394941	Service set GM 4600/4700AC

◆ = Wearing part

★ = Included in service set

● = Not part of the standard equipment but available as a special accessory.

15 WARRANTY AND CONFORMITY DECLARATIONS

15.1 IMPORTANT NOTES REGARDING PRODUCT LIABILITY

As a result of an EC regulation effective from January 1, 1990, the manufacturer shall only be liable for his product if all parts originate from him or are approved by him, and if the devices are properly mounted, operated and maintained.

The manufacturer will not be held liable or will only be held partially liable if third-party accessories or spare parts have been used.

With genuine WAGNER accessories and spare parts, you have the guarantee that all safety regulations are complied with.

15.2 WARRANTY CLAIM

Full warranty is provided for this device:

We will at our discretion repair or replace free of charge all parts which within 24 months in single-shift, 12 months in 2-shift or 6 months in 3-shift operation from date of receipt by the purchaser are found to be wholly or substantially unusable due to causes prior to the sale, in particular faulty design, defective materials or poor workmanship.

The type of warranty provided is such that the device or individual components of the device are either replaced or repaired as we see fit. The resulting costs, in particular shipping charges, road tolls, labour and material costs will be borne by us except where these costs are increased due to the subsequent shipment of the device to a location other than the address of the purchaser.

We do not provide warranty for damage that has been caused or contributed to for the following reasons:

Unsuitable or improper use, faulty assembly or commissioning by the purchaser or a third party, normal wear, negligent handling, defective maintenance, unsuitable coating products, substitute products and the influence of chemical, electrochemical or electrical agents, except when the damage is attributable to us.

Abrasive coating products such as red lead, emulsions, glazes, liquid abrasives, zinc dust paints and so forth reduce the service life of valves, packings, spray guns, nozzles, cylinders, pistons etc. Signs of wear traced back to these products are not covered by this warranty. Components that have not been manufactured by WAGNER are subject to the original warranty of the manufacturer.

Replacement of a component does not extend the period of warranty of the device.

The device should be inspected immediately upon receipt. To avoid losing the warranty, we or the supplier company are to be informed in writing about obvious faults within 14 days upon receipt of the device.

We reserve the right to have the warranty compliance met by a contracting company.

The services provided by this warranty are dependent on evidence being provided in the form of an invoice or delivery note. If the examination discovers that no warranty claim exists, the costs of repairs are charged to the purchaser.

It is clearly stipulated that this warranty claim does not represent any constraint on statutory regulations or regulations agreed to contractually in our general terms and conditions.

15.3 CE DECLARATION OF CONFORMITY

Herewith we declare that the supplied version of

GM 4700AC 25 MPa
GM 4700AC-H 25 MPa



complies with the following guidelines:

2006/42/EC
94/9/EC

Applied standards, in particular:

DIN EN ISO 12100: 2010	DIN EN 13463-5: 2011
DIN EN 1127-1: 2011	DIN EN ISO 13732-1: 2008
DIN EN 1953: 2013	DIN EN ISO 4414: 2010
DIN EN ISO 14462: 2005 + A1 2009	DIN EN ISO 4413: 2010
DIN EN 13463-1: 2009	

Applied national technical standards and specifications, in particular:

BGR 500 Part 2, Chapter 2.36	BGI 740
BGR 500 Part 2, Chapter 2.29	ZH 1/406
TRBS 2153	

EC Certificate of Conformity

The CE certificate of conformity is enclosed with this product. If needed, further copies can be ordered through your WAGNER dealer by specifying the product name and serial number.

Order number: 2316429

15.4 REFERENCE TO GERMAN REGULATIONS AND GUIDELINES

- a) BGR 500 Part 2, Chapter 2.36 "Working with Liquid Ejection Devices"
- b) BGR 500 Part 2, Chapter 2.29 "Working with Coating Products"
- c) TRBS 2153 Avoiding ignition risks
- d) BGI 740 Painting rooms and equipment
- e) ZH 1/406 Guidelines for liquid ejection devices

Note: All titles can be ordered from Heymanns Publishing House in Cologne, or they can be found on the Internet.

WAGNER

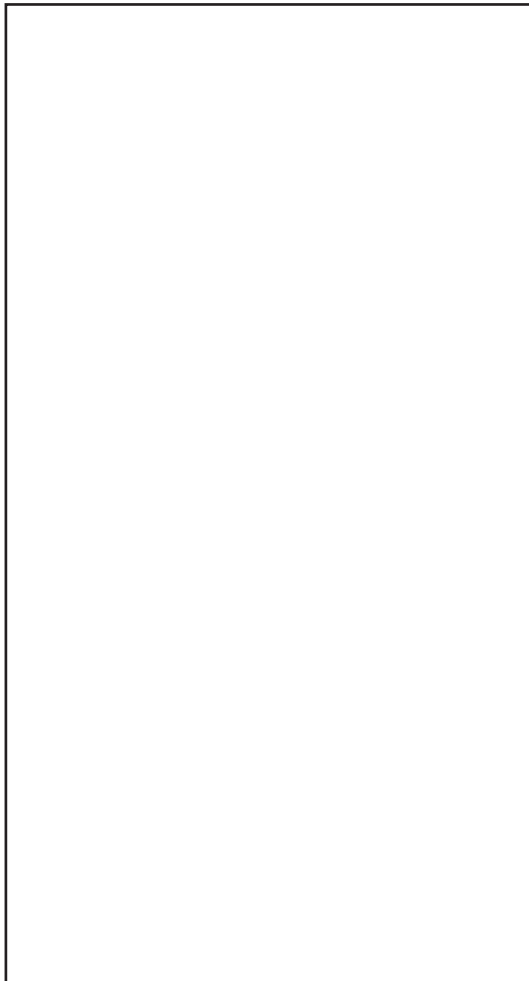

Order No. 2311730

Edition 04/2016

Germany

J. WAGNER GmbH

Otto-Lilienthal-Str. 18

Postfach 1120

D- 88677 Markdorf

Phone +49/ (0)7544 / 5050

Telefax +49/ (0)7544 / 505200

E-mail service.standard@wagner-group.com

Switzerland

J. WAGNER AG

Industriestrasse 22

Postfach 663

CH- 9450 Altstätten

Phone +41/ (0)71 / 757 2211

Telefax +41/ (0)71 / 757 2222

More contact addresses on the internet at:

www.wagner-group.com

Company/Locations/WAGNER worldwide

Subject to changes without notice